

W2CB / X-Y Axis Connection

W2CB - XX - XXXX - XXX - XX - XXXX - XXX - XX - X

- 1
 - 2
 - 3
 - 4
 - 5
 - 6
 - 7
 - 8
 - 9
- Model Size Stroke Y Axis Lead Y Axis Y Axis Mounting Kit Side Stroke X Axis Lead X Axis X Axis Mounting Kit Side Motor Position

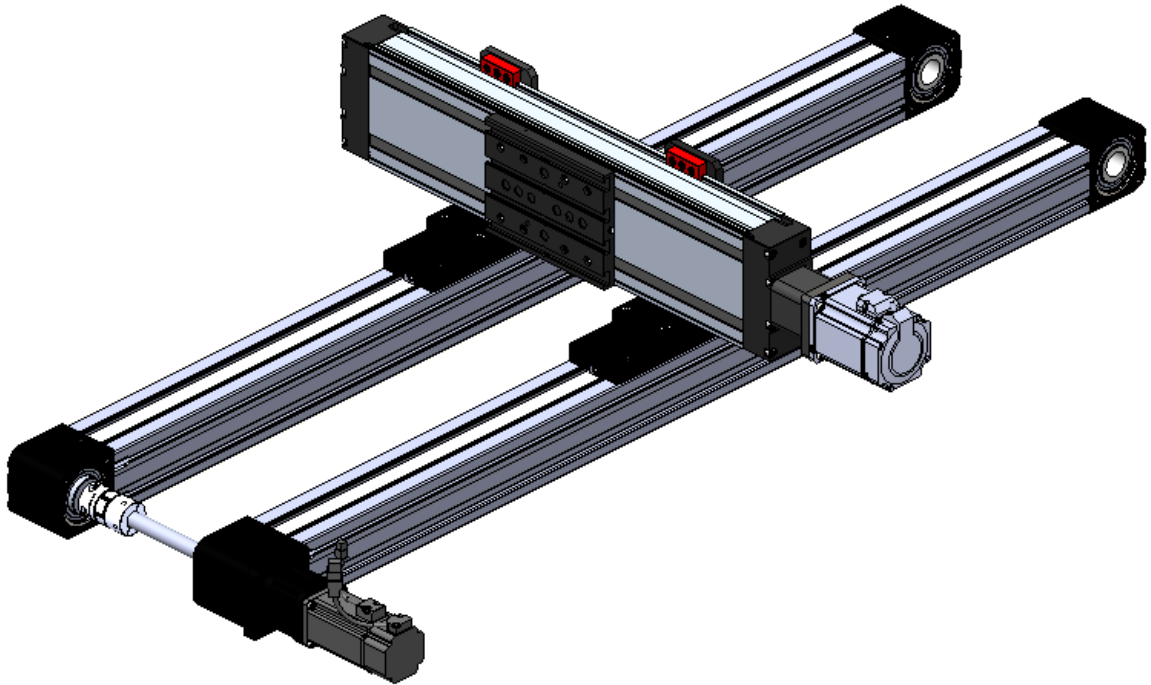

Type	Axis	Linear axis	Lead	Smin (mm)	Smax (mm)	mex max (kg)
W2CB-01	Y	WMCD-145	5 mm	400	1400	69
			10 mm			
	20 mm					
	X	WMCS-080	200 mm/rev	100	2750	
W2CB-02	Y	WMCD-110	5 mm	300	1523	25
			10 mm			
	16 mm					
	X	WMCS-065	140 mm/rev	170	2750	

Drive Model

W2CB WDAK / WDPK - Mounting Kit

W2CB-XX-XXXX-XX-00-XXXX-XXX-00-0

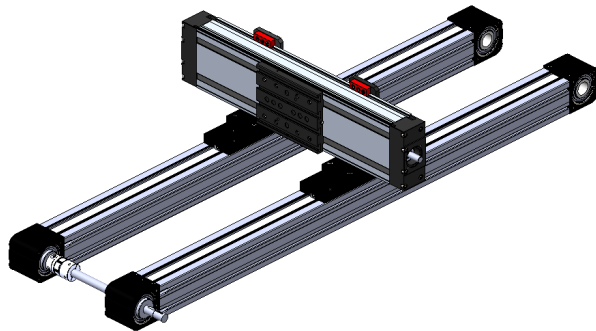

W2CB-XX-XXX-XX-01-XXXX-XXX-01-R

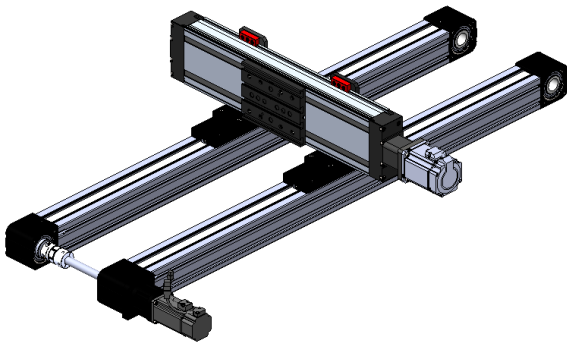

W2CB-XX-XXX-XX-01-XXXX-XXX-01-L

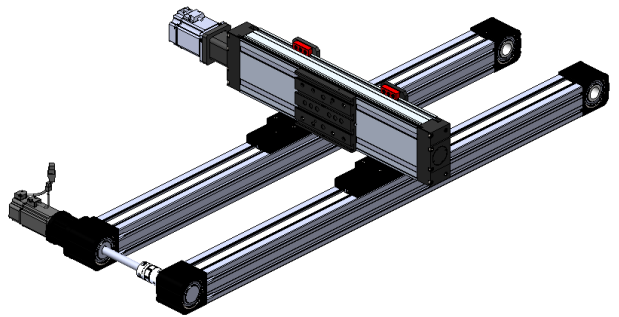

W2CB-XX-XXXX-XX-02-XXXX-XXX-01-R

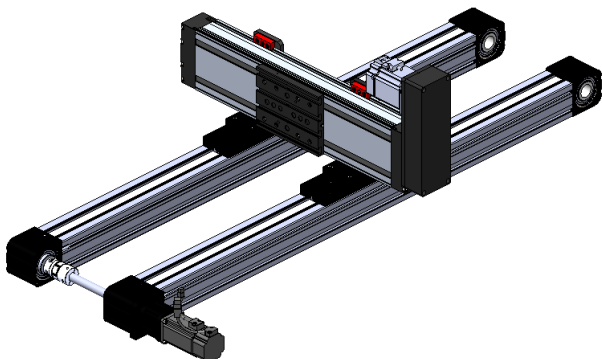

W2CB-XX-XXXX-XX-03-XXXX-XXX-01-R

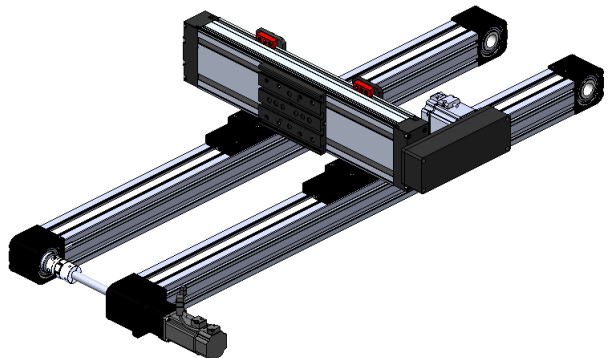

Technical Drawing

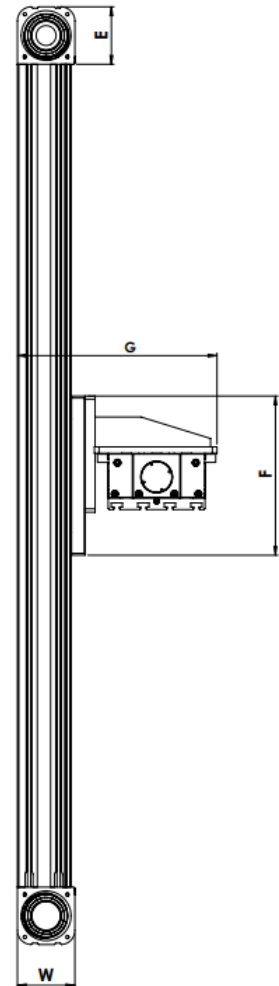
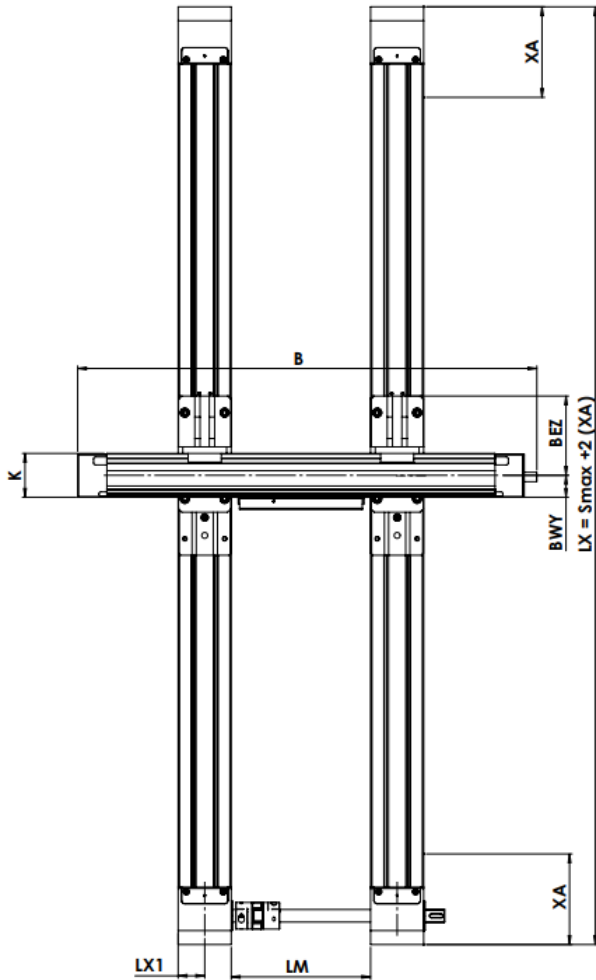

	AXIS	LINEAR AXIS
W2CB-01	X	WMCS-080
	Y	WMCD-145
W2CB-02	X	WMCS-065
	Y	WMCD-110

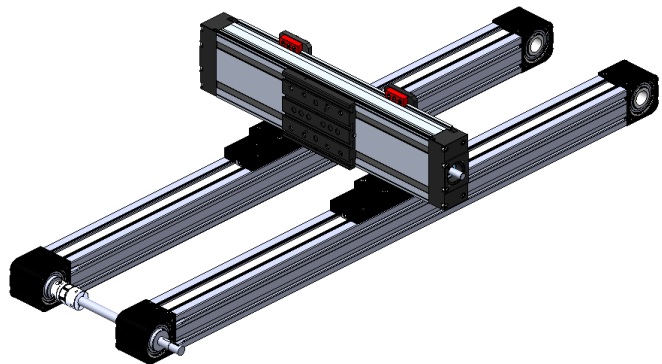

TYPE	XA	B	BEZ	BWY	K	LX1	E	G	F
W2CB-01	136,5	307 + STROK	103	32,5	65	40	86,5	301	240
W2CB-02	115	266 + STROK	95	24,5	49	32	65	243	190

W2CB Assembly Parts

W2CB ASSEMBLY PARTS

	CODES	DETAIL VIEW
<p>W2CB-01 ASSEMBLY PARTS</p>	<p>198899</p>	
<p>W2CB-02 ASSEMBLY PARTS</p>	<p>198906</p>	