

WINMAN WPNC-032 Serisi Pin Klemp Silindirler / WPNC-032 Series Pin Clamp Cylinders

Opsiyon / Option

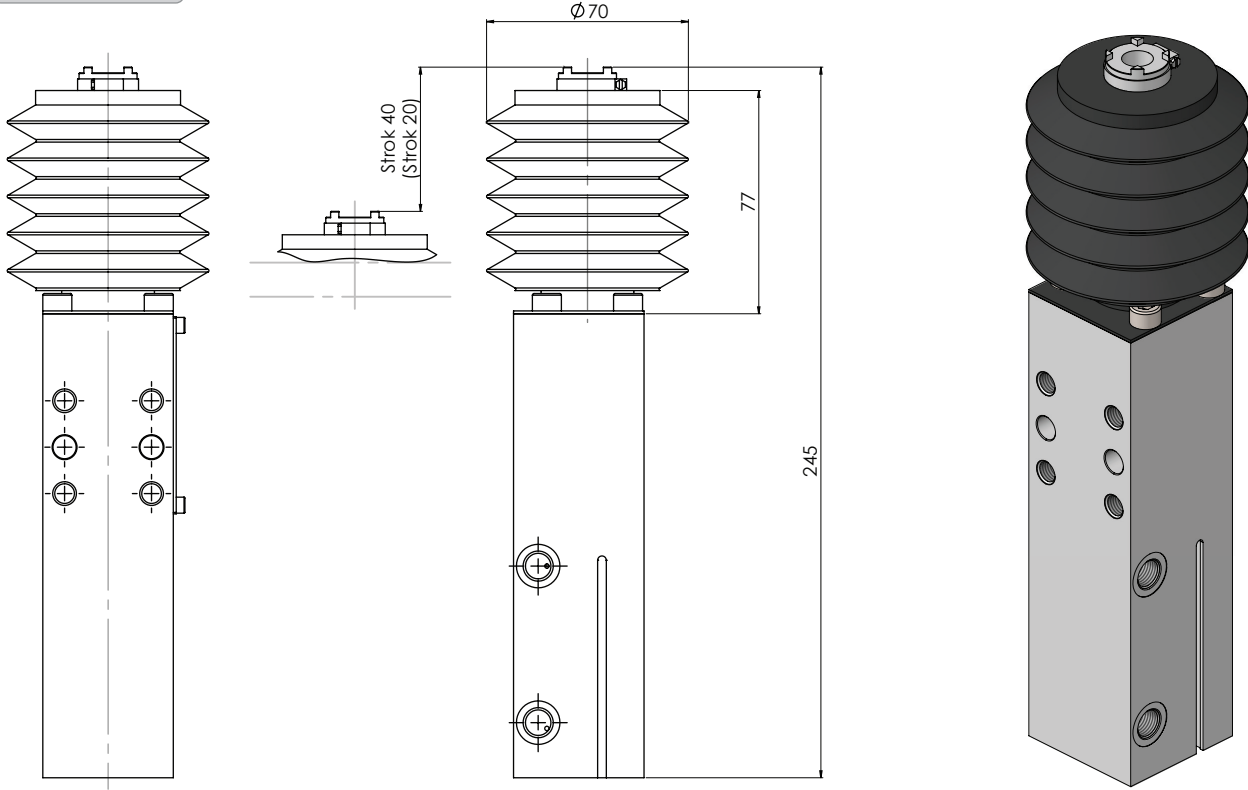

Kesme Kuvveti / Shear Force

 Piston Kolu Max. Merkezi Sapma
 Max. Deviation Piston Rod Centric

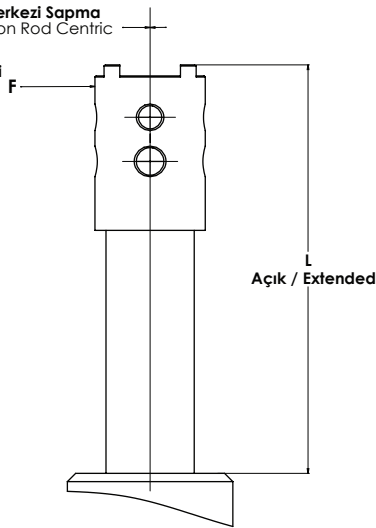
 Kesme Kuvveti
 Shear Force

Model Model	Kesme Kuvveti Shear Force [N]	L [N]	Strok Stroke [mm]	Sapma Deflection [mm]
20	200	75	20	0,07
	150			0,06
	100			0,05
	75			0,05
40	200	55	40	0,12
	150			0,10
	100			0,08
	75			0,06