

WINMAN WPNC-040 Serisi Pin Klemp Silindirler / WPNC-040 Series Pin Clamp Cylinders

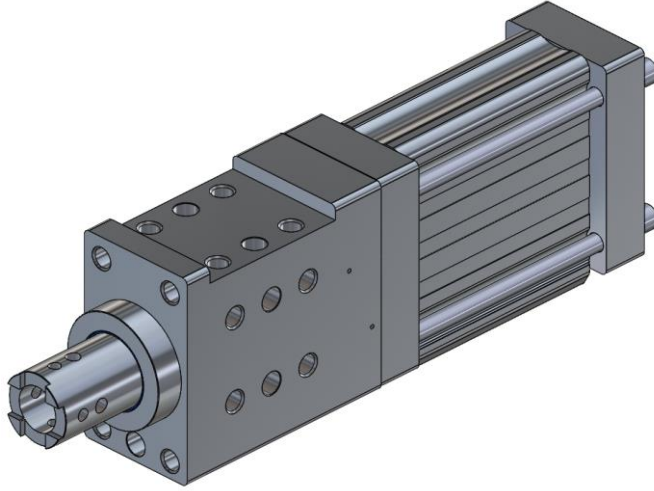

Özellikler / Specification

Piston Çapı / Bore Size	40	
Çalışma Tipi / Acting Type	Çift Etkili / Double Acting	
Akışkan / Fluid	Hava (40mm filtrelenmiş) / Air (40µm filtered)	
Çalışma Basıncı / Op. Pressure	<10 Bar	
Sıcaklık / Temperature	0~80°C	
Manyetik / Magnetic	Standart / Standard	
Yastıklama Tipi / Cush. Type	Damper / Bumper	
Hız / Speed Range	< 500 mm / s	
Sensör / Sensor Switches	WT-1001D, WT-07, WT-37, WT-36	
İtme Kuvveti / Pushing Force	620 N (5 Bar)	
Geri Çekme Kuvveti / Retraction Force	520 N (5 Bar)	
Strok / Stroke	20 mm	40 mm
Ağırlık / Weight	1600 gr	2000 gr
5 bar'da Çift Strok Başına Hava Tüketimi Air Consumption Per Double Stroke at 5 Bar	0,5 dm ³	0,7 dm ³

Teknik Çizim / Technical Drawing

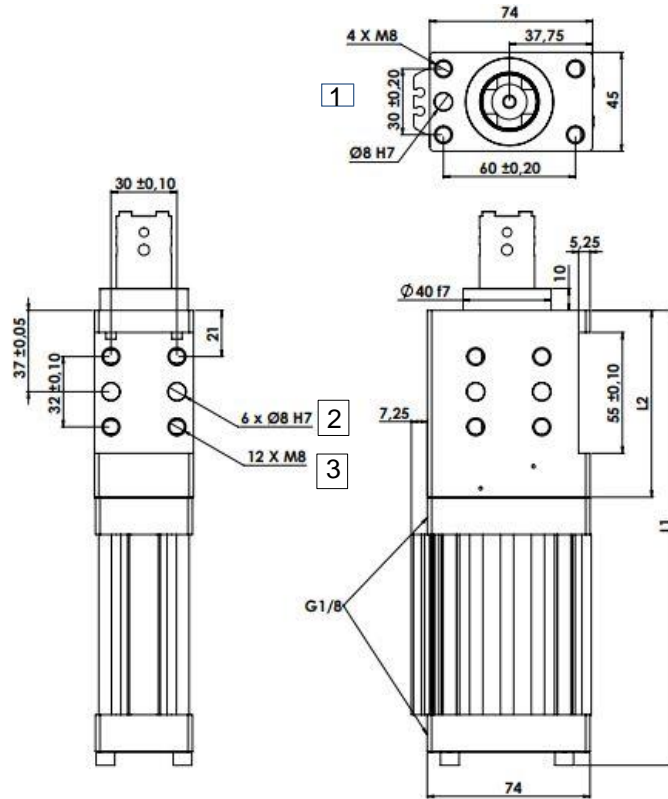
1 - Manyetik sensör için kanal.

 Sensor slot for magnetic switch.
Her iki yüzeyde mevcuttur.
Available on both surfaces.

2 - Montaj pim delikleri

Mounting pin hole

3 - Montaj bağlantı delikleri

Mounting connection hole

Opsiyonlar ve farklı stroklar için bilgi alınız.
Get information about options and different strokes.

Strok/ Stroke	L1	L2
20	207	95
40	207	95

Sipariş Kodu / Ordering Code

MODEL MODEL	MANYETİK MAGNETIC	ÇAP DIA.	STROK STROKE
WPNC	M	040	020
PARALEL TUTUCU Parallel Grippers	M: MANYETİK M: With Magnet I: ENDÜKTİF I: With Inductive	PİSTON ÇAPI (mm) Piston Dia.	STROK (mm) Stroke

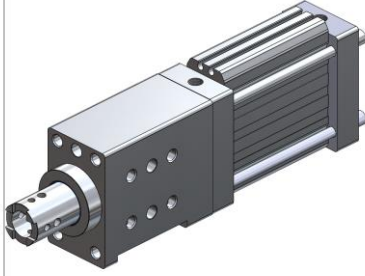
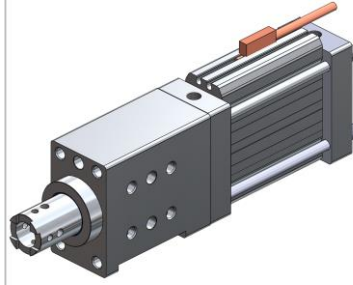
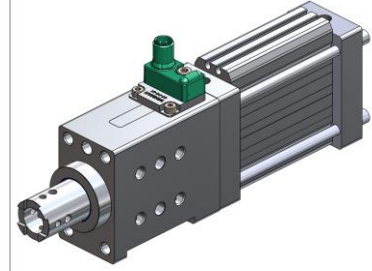
WINMAN WPNC-040 Serisi Pin Klemp Silindirler / WPNC-040 Series Pin Clamp Cylinders
Opsiyon / Option
01 Sensörsüz
01 Sensorless

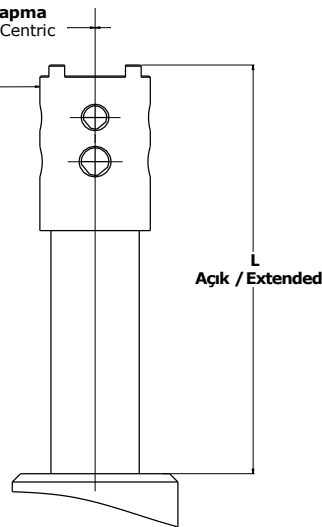
02 Manyetik Sensör
02 Magnetic Sensor

03 Endüktif Sensör
03 Inductive Sensor

Kesme Kuvveti / Shear Force
Piston Kolu Max. Merkezi Sapma
Max. Deviation Piston Rod Centric

Kesme Kuvveti
Shear Force **F**

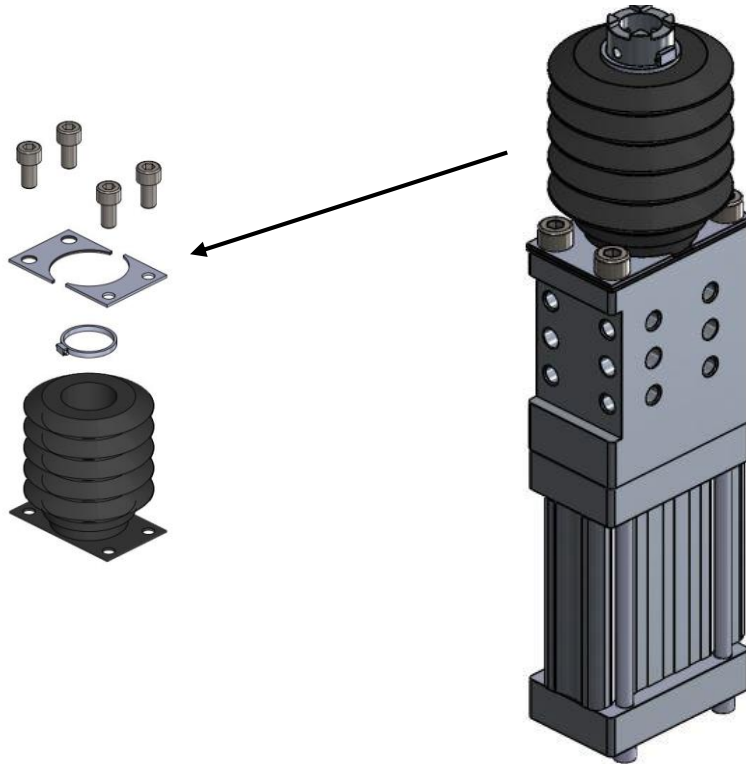
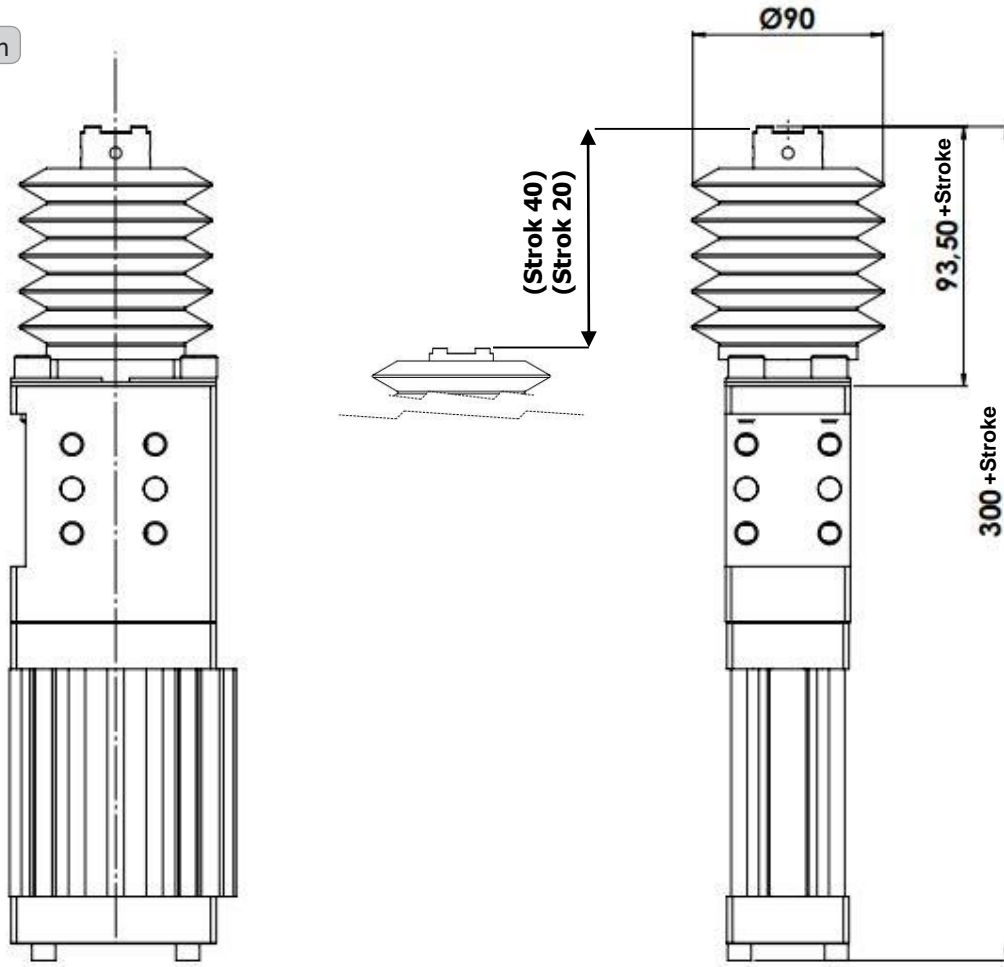
Model Model	Kesme Kuvveti Shear Force [N]	L [N]	Strok Stroke [mm]	Sapma Deflection [mm]
20	200	52	20	0,06
40	200	70	40	0,09

WINMAN WPNC-040 Serisi Pin Klemp Silindirler / WPNC-040 Series Pin Clamp Cylinders

Opsiyon / Option



WINMAN WPNC-040 Serisi Pin Klemp Silindirler / WPNC-040 Series Pin Clamp Cylinders

Endüktif Sensör Sistem
Inductive Sensing System

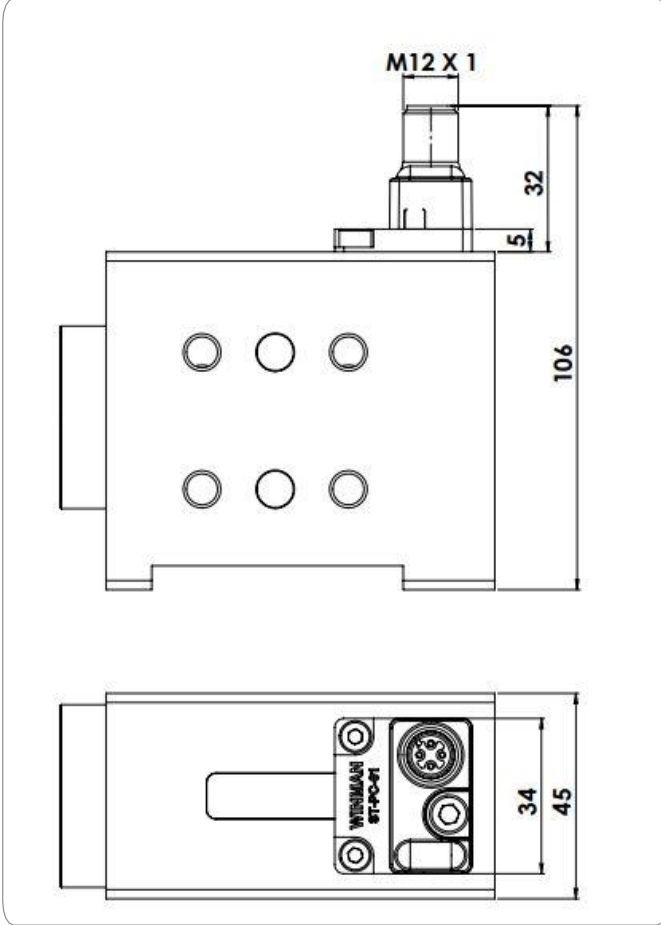

Sensör Kablo Aksesuarları
Sensor Cable Accessories

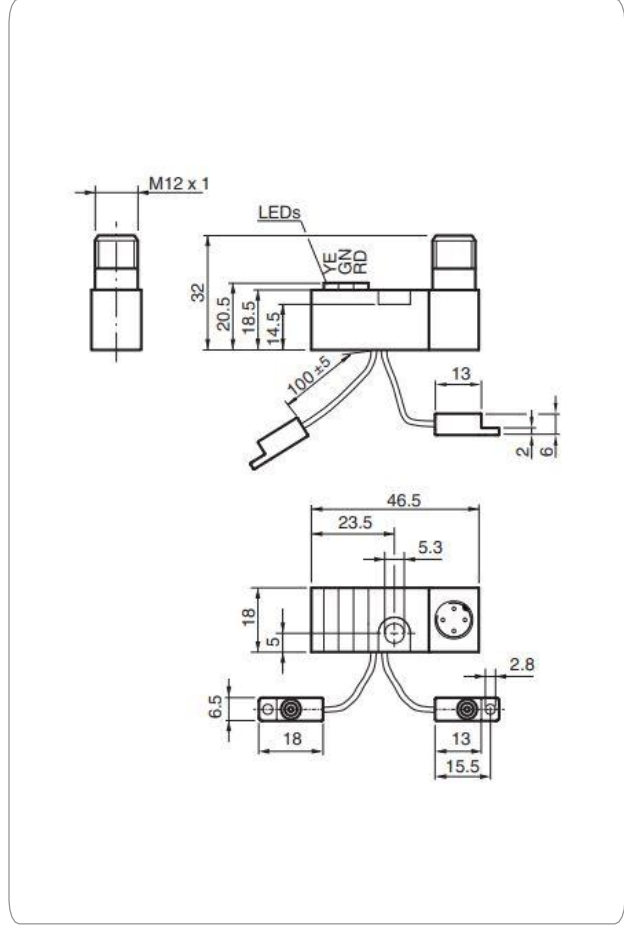

Endüktif Sensör Bağlantı Şeması
Inductive Sensor Wiring Diagram

