

Sipariş Kodu / Ordering Code

WMOS - TB - 040 -

1

 Model
Model

2

 Tahrik Birimi
Drive Unit

3

 Boyut
Size

4

 Strok
Stroke

5

 İlerleme
Lead

6

 Tahrik Yönü
Driving Side

7

 Bağlantı Kiti Modeli
Mounting Kit Model

8

 Bağlantı Kiti Montaj
Mounting Kit Assembly

1 - Model / Model

WMOS: Kayışlı Modül / Belt Driven Linear Module

2 - Tahrik Birimi / Drive Unite

TB: Triger Kayış / Timing Belt

3 - Boyut / Size

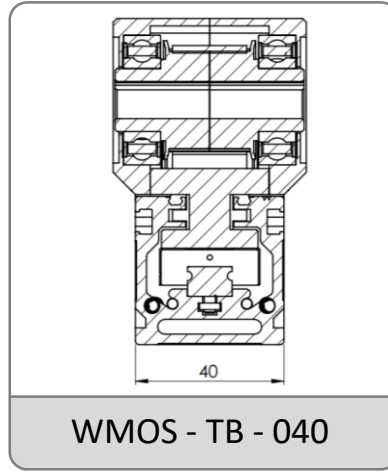

4 - Strok / Stroke

0000: Maksimum 2685 mm / Maximum 2685 mm
Haraket Stroku / Movement Stroke

İstenilen çalışma stokuna ek olarak Ss ölçüsü kadar her iki tarafta da boşluk bırakılması tavsiye edilir.
In addition to the desired movement stroke, it is recommended to leave a space on both sides until Ss.

$$S_m = S_e + 2.S_s$$

$$S_s = 50 \text{ mm}$$

S_m : Haraket Stroku / Movement Stroke
S_e : Etkin Hareket Stroku / Safety Stroke

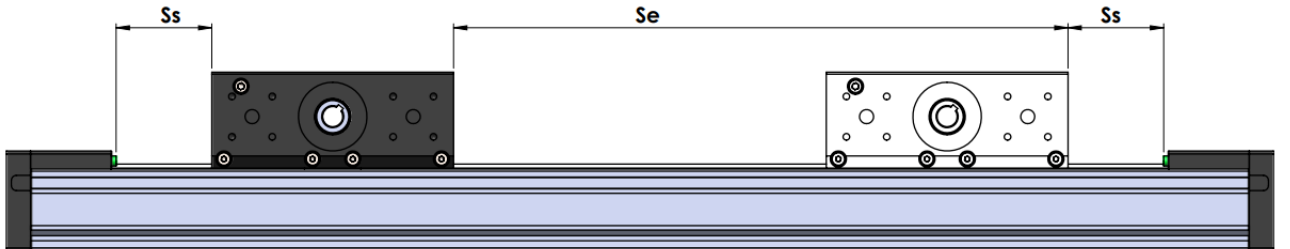

5 - İlerleme / Lead

90 : 90 mm/devir / 90 mm/rev

Sipariş Kodu / Ordering Code

WMOS - TB - 040 -

1

Model
Model

2

Tahrik Birimi
Drive Unit

3

Boyut
Size

4

Strok
Stroke

5

İlerleme
Lead

6

Tahrik Yönü
Driving Side

7

Bağlantı Kiti Modeli
Mounting Kit Model

8

Bağlantı Kiti Montaj
Mounting Kit Assembly

6 - Tahrik Yönü / Ordering Code

00 - Standart / Standard



01

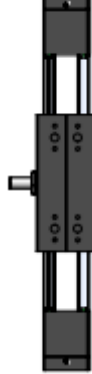

02



7 - Bağlantı Kiti Modeli / Mounting Kit Model

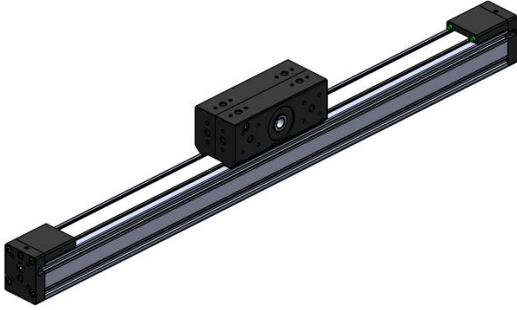

00 : Bağlantı Kitsiz (STANDART)
Without Mounting (Standard)

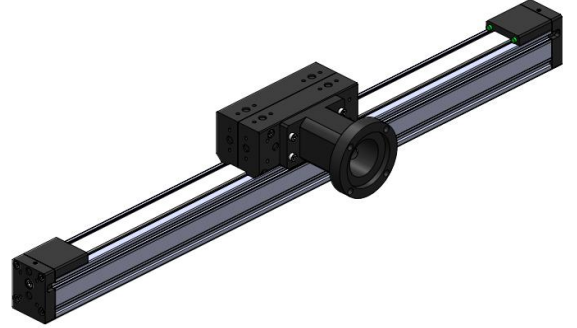

01 : WDAK Eksenel Kit
Axial Kit

Not 1 : Farklı motor tipleri ve ölçüleri için irtibata geçiniz. Note 1 : Please contact for different motor types and mounting sizes.

Not 2 : Redüktörlü ürünler kullanmak için irtibata geçiniz. Note 2 : Please contact for to use gearbox.

8 - Bağlantı Kiti Montaj / Mounting Kit Assembly

00 : Motorsuz (Standart)
Without Motor (Standard)

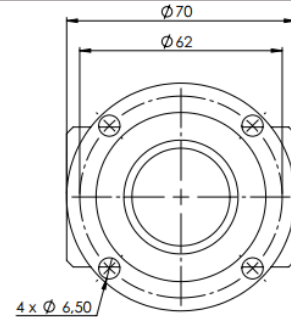

070 : Ø70 redüktör bağlantısı
Ø70 reducer mounting

WINMAN WMOS-040 Serisi Omega Kayışlı Modüller / WMOS-040 Series Omega Belt Driven Linear Modules



Özellikler / Specification		Sürücü Bloğundan Montaj Mounting by the Drive Block	Profilden Montaj Mounting by the Profile
Maksimum Strok / Maximum Stroke [mm]		880	2685
Minimum Strok / Minimum Stroke [mm]		60	
Tekrarlama Hassasiyeti / Repeating Accuracy [mm]		< 0,1	
Çalışma Hızı / Speed [m/s]		≤ 5,0	
İvmelenme Max / Acceleration [m/s ²]		50	
Dinamik Yük Kapasitesi / Dynamic Load Capacity [Nm]		Dinamik Moment Kapasitesi / Dynamic Torsional Moment Load Capacity [Nm]	
C		M _t	M _L
5266		31	118

Eksenlerde İzin Verilen Maximum Moment / Maximum Permissible Torsional Moment Around The Axis [Nm]			Eksenlerde Maximum Dinamik Yük / Maximum Dynamic Load in Directions [Nm]	
M _x max	M _y max	M _z max	F _y max	F _z max
15	39	61	2650	1725

Not : Verilen değerler teorik değerlerdir. Emniyet katsayısını 5 almanızı öneririz.

Note : Calculated value are theoretical values. We recommend you to calculate safety factor as five (5).

Teknik Çizim / Technical Drawing

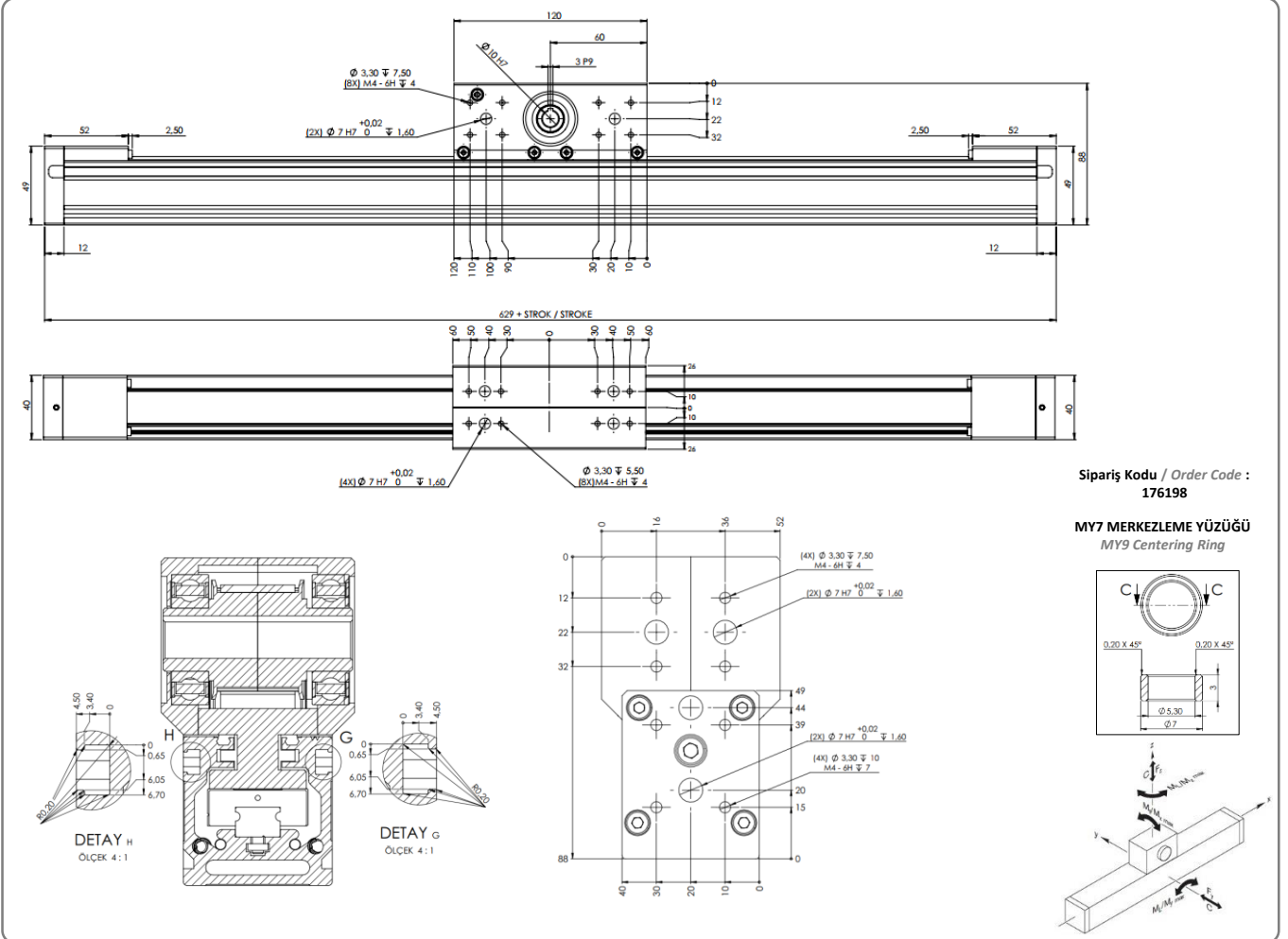

Sipariş Kodu / Order Code :
176198

MY9 MERKEZLEME YÜZÜĞÜ
MY9 Centering Ring

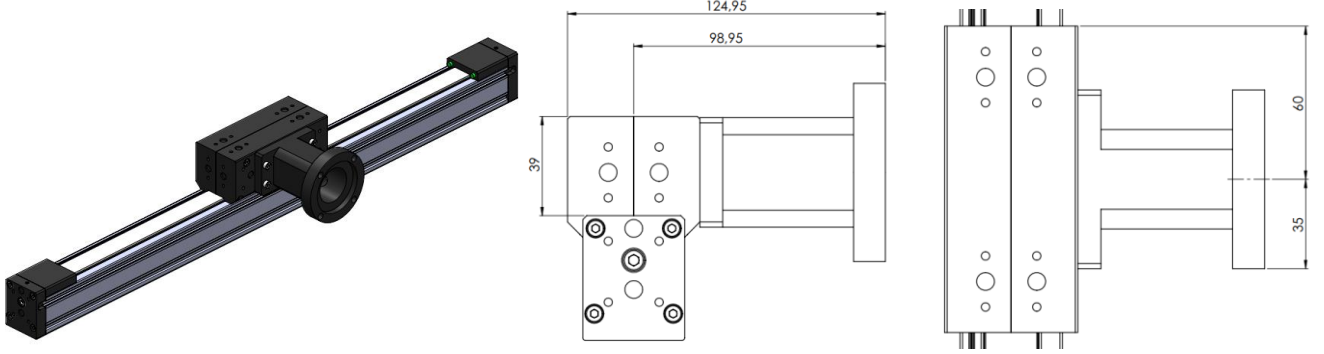
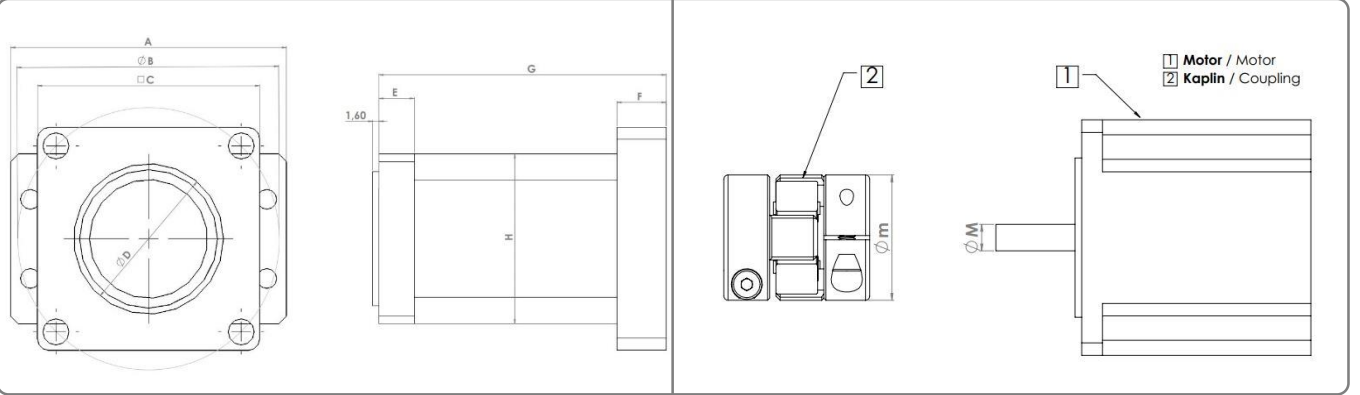
WDAK Eksenel Bağlantı Kiti / WDAK Axial Mounting Kit
Teknik Çizim / Technical Drawing

Kampana - Kaplin / Bellhousing - Coupling
Motor Bağlantı / Motor Mounting

Motor Tipi Motor Type	A	B	C	D	E	F	G	H
WDAK - 070	70	66	57	38	9	12,5	73	43

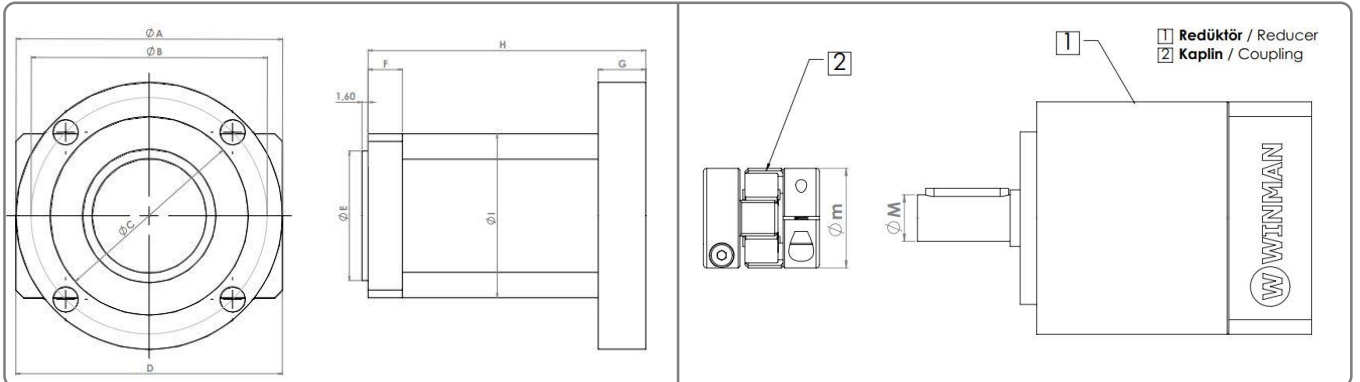
Motor Tipi Motor Type	M	m	Kaplin Modeli Coupling Model
WDAK - 070	19	40	WWJC - 30CRD

Redüktör Bağlantı / Reducer Mounting

Motor Tipi Motor Type	A	B	C	D	E	F	G	H	I
WDAK - 070	70	62	52	70	34	9	12,5	73	43

Motor Tipi Motor Type	M	m	Kaplin Modeli Coupling Model
WDAK - 070	14	30	WWJC - 30CRD

Montaj / Assembly

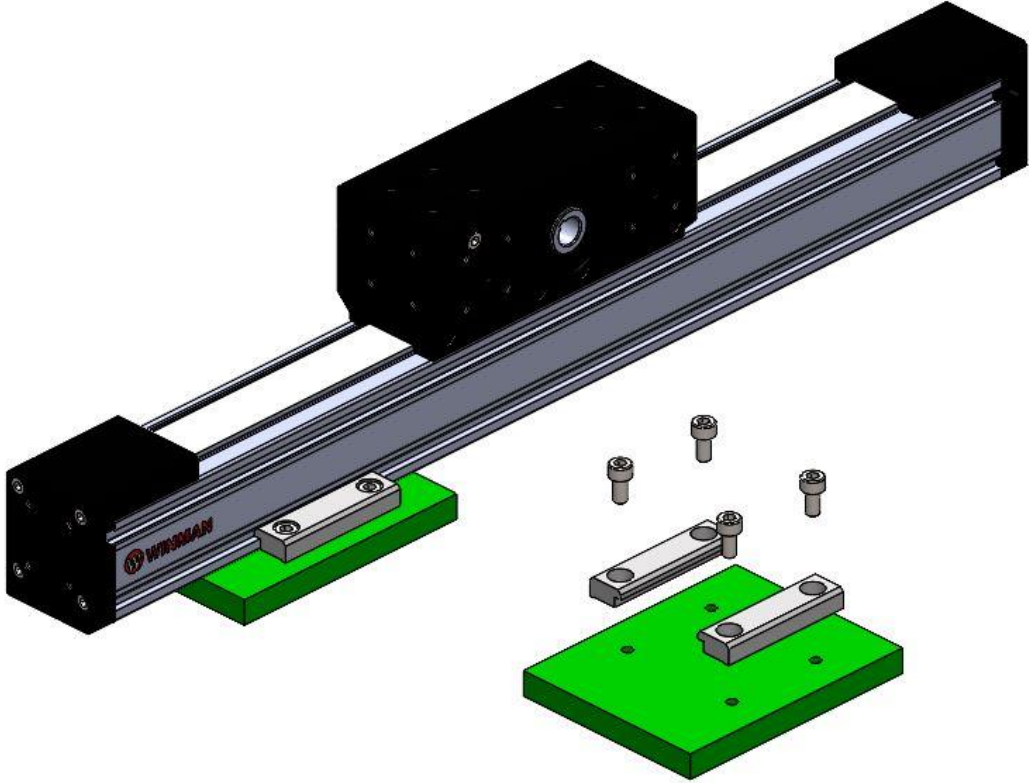

Sipariş Kodu / Order Code : 176194

Montaj Bağlantı Aparatı / Mounting Bracket

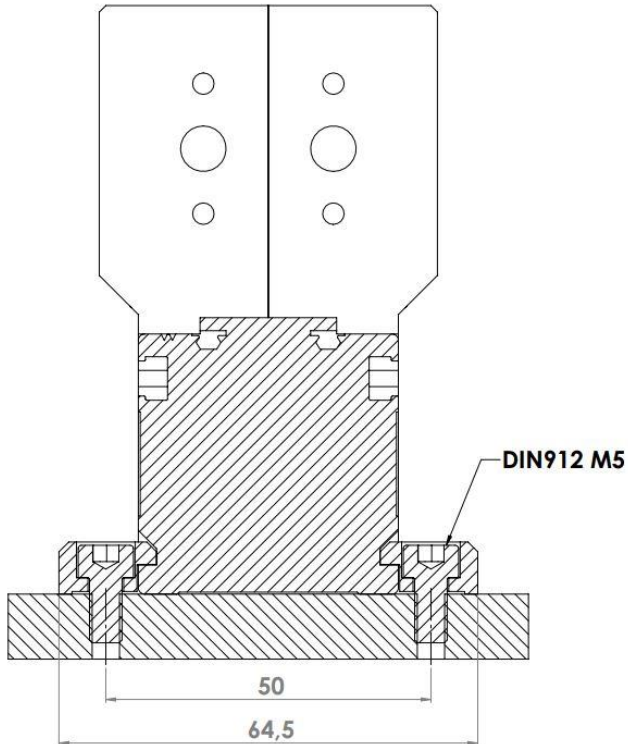

WMOS 040 Sabitleme Braketi
Clamping Fixtures

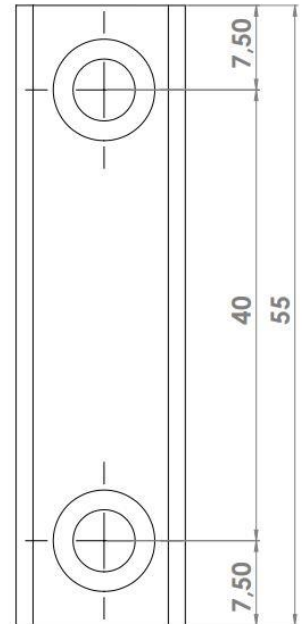

Montaj / Assembly

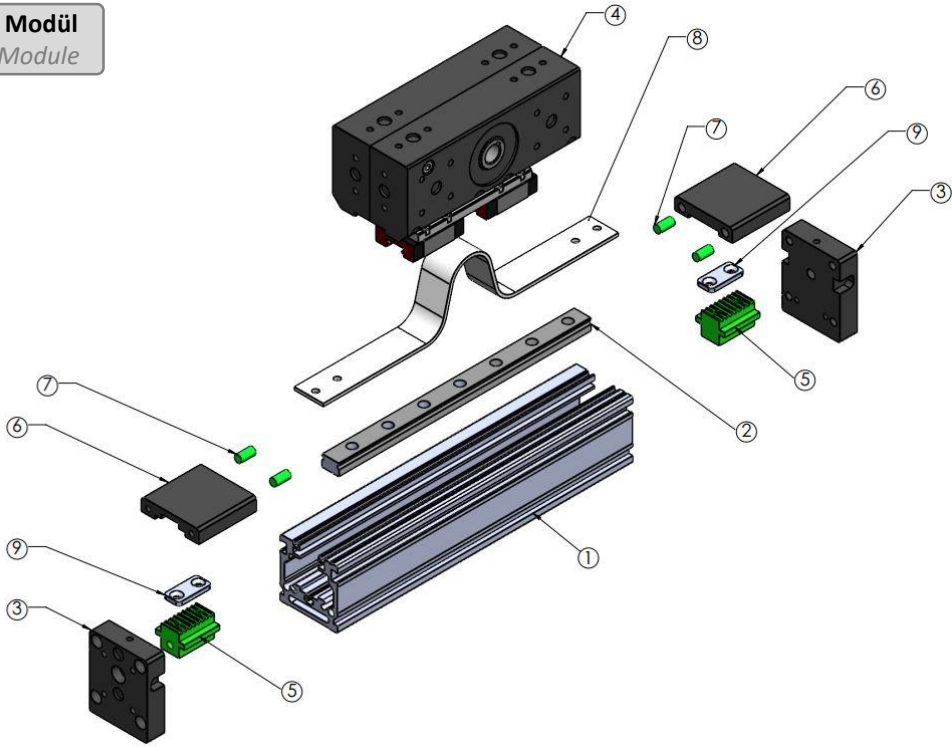
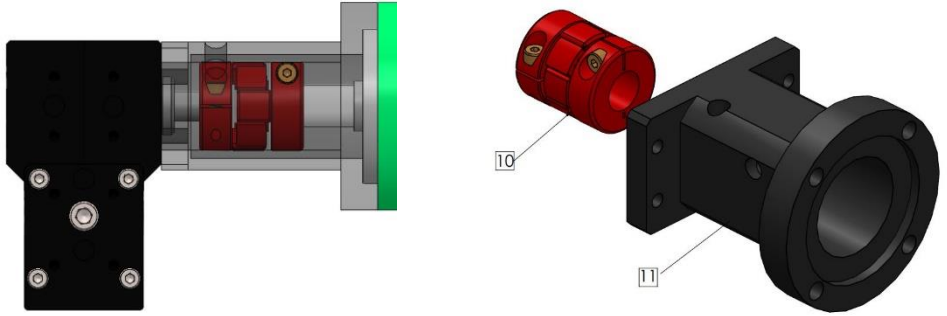
WMOS Linear Modül
WMCS Linear ModuleWDAK Eksenel Kit
WDAK Axial Kit

Parça / Piece	Miktar / Qty	Parça Adı / Part Name	Montaj / Assembly
1	1	Profil / Profile	Modül Module
2	1	Lineer Ray / Ball Screw	
3	2	Kapak / Block	
4	1	Bağlantı Plakası / Mounting Plate	
5	2	Kayış Bağlantı Parçası / Belt Mounting Parts	
6	2	Kapak Parça / Block Part	
7	4	Kapak Tutucu / Block Holder	
8	1	Kayış / Belt	
9	2	Kayış Bağlantı Parçası / Belt Mounting Parts	
10	1	Kaplın / Coupling	Eksenel Kit Axial Kit
11	1	Kampana / Kampana	

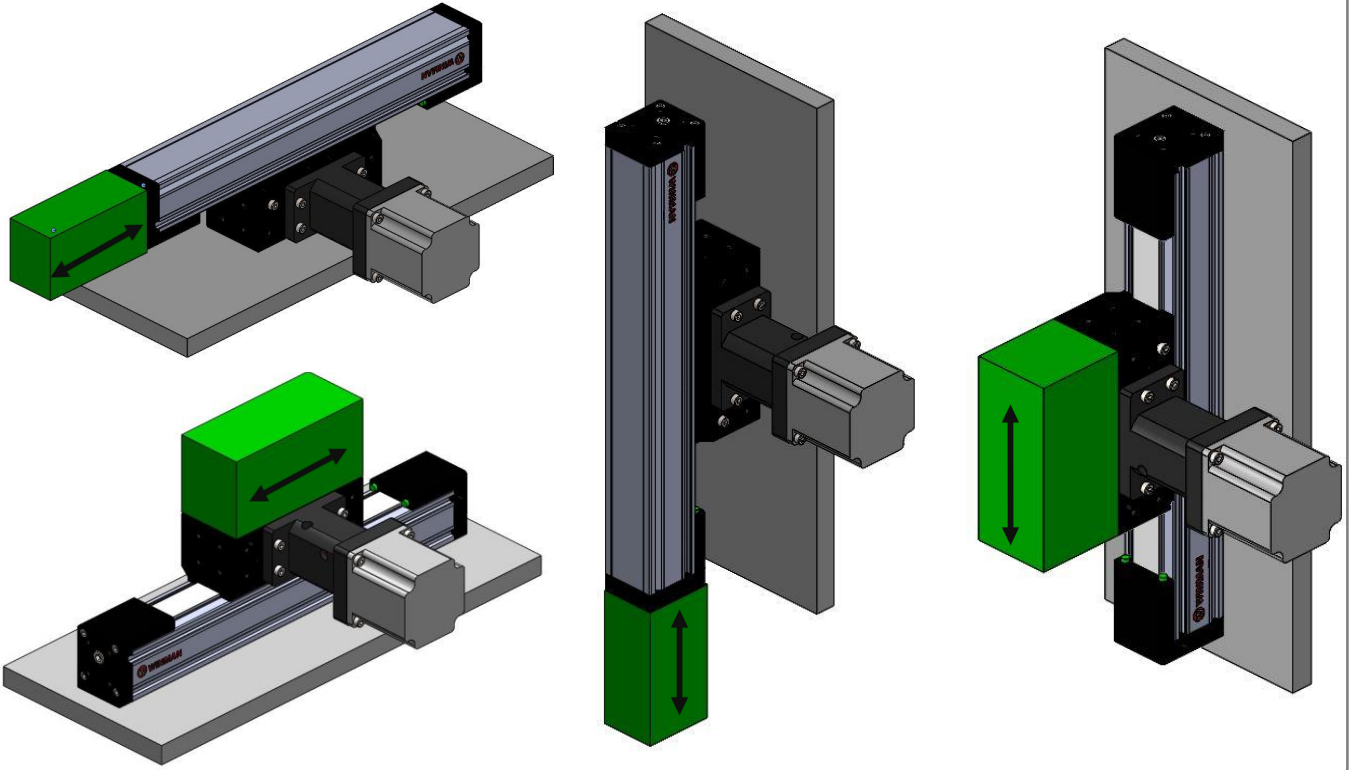
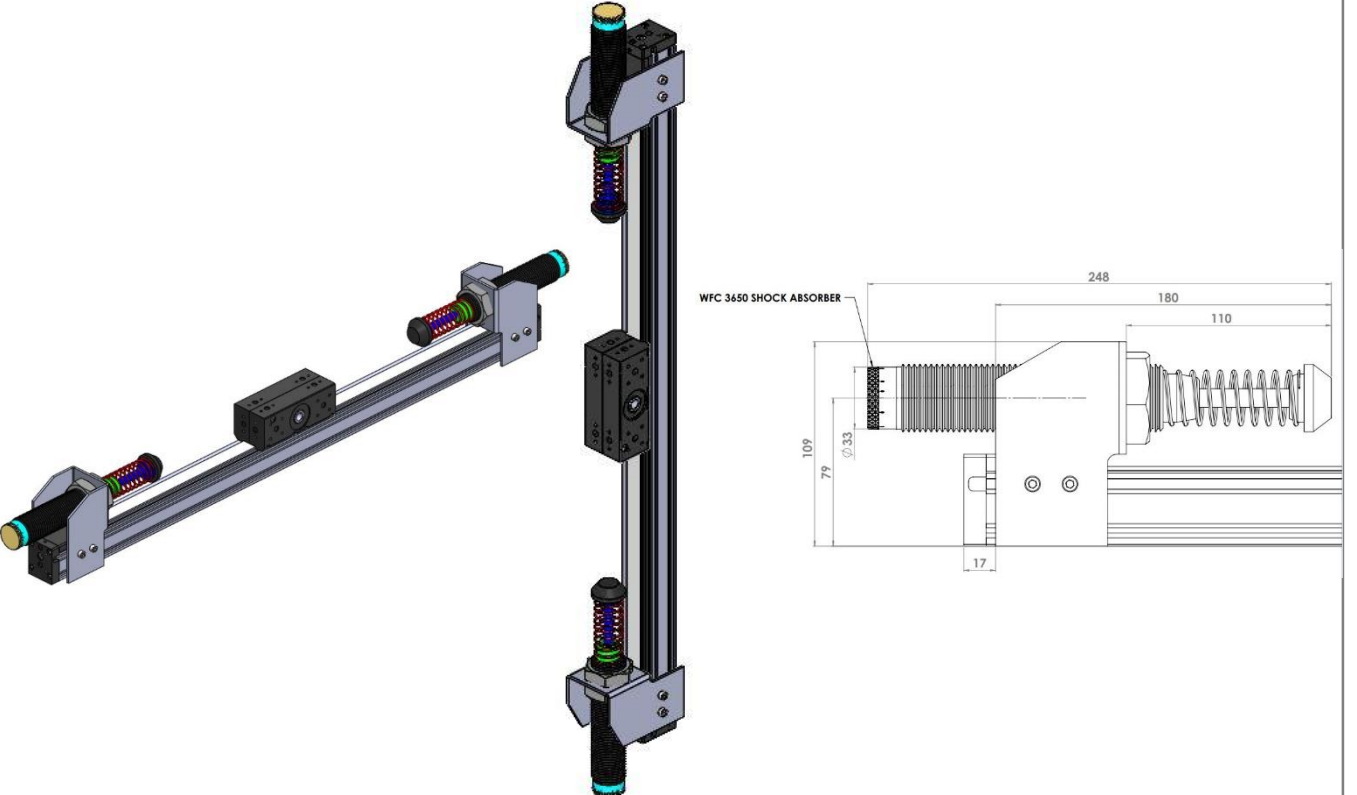
Montaj Bağlantı Eksenleri / Mounting Orientation Horizontal**Şok Emici / Shock Absorber**

Bakım / Maintenance

- İlk yağlama montaj sırasında yapılır.

Basic lubrication is done in-factory before shipment.

- Taşıyıcıdaki dişli kasnakları yataklayan rulmanlar normal çalışma koşullarında tekrardan yağlama gerektirmez.

The bearings that support the gear pulleys on the carrier are not necessary relubricating under normal operating conditions.

- Omega modüller sadece uygun gres yağlar ile yağlanmalıdır.

Omega Modules are designed for grease lubricants only!

- Lityum içerikli gres yağlar kullanılmalıdır.

Lithium soap grease should be used.

- Dikkat: grafit ya da MoS içeren gresler tercih etmeyiniz!

Caution: Do not use grease containing graphite or MoS!

- Yağlama, her 400 çalışma saatinde ya da 800km çalışma mesafesine ulaşıldığında yapılır.

Lubrication is performed every 400 hours or 800 km total working distance by normal operating conditions.

- Yağlama miktarı normal çalışma koşullarına göre tabloda verilmiştir.

Lubrication quantity is provided in table by normal operating conditions.

- Yağlamadan sonra lineer modülü, strok mesafesi boyunca en az üç kez hareket ettirin. Bu esnada hareket hızı 10 mm/s değerini aşmamalıdır.

After lubrication, move the linear module along the stroke distance at least three times. Meanwhile, the moving speed should not exceed 10 mm/s.

Normal Çalışma Koşulları / Normal Working Conditions

Not : Tabloda belirtilen yağlama miktarı normal çalışma koşulları için geçerlidir. Farklı çalışma koşullarında yağlama miktarı değişkenlik gösterebilir. Farklı çalışma şartlarında ki yağlama miktarı için bilgi alınız.

Note : The lubrication quantity specified in the table is valid for normal operating conditions. The lubrication quantity may vary in different operating conditions. Get information for the lubrication quantity in different working conditions.

Ortam Sıcaklığı / Ambient Temperature	°C	10 ~ 40
Çalışma Hızı / Speed	m/s	≤ 3,0
Yük / Load	kN	≤ 0,2 C
Strok / Stroke	mm	> 25
Yağlama Periyodu / Lubrication Period	km	800
	hour	400
Yağlama Miktarı / Lubrication Dose	cm ³	0,7

Bu katalogta yayınlanan resim, ölçü ve diğer değerleri firmamız değiştirme hakkına sahiptir.

Our company has the right to modify change images, dimensions and other datas which take place in this catalogue.