

Sipariş Kodu / Ordering Code

WMCD - BS - 110 -

1	2	3	4	5	6	7	8
Model Model	Tahrik Birimi Drive Unit	Boyut Size	Strok Stroke	Hatve Pitch	Bağlantı Kiti Modeli Mounting Kit Model	Bağlantı Kiti Montaj Mounting Kit Assembly	Bağlantı Kiti Yönü Mounting Kit Side

1 - Model / Model

WMCD : Kompakt Lineer Modül / *Compact Linear Module*

2 - Tahrik Birimi / Drive Unit

BS : Vidalı Mil / *Ball Screw*

3 - Boyut / Size

Standart / Standard

110

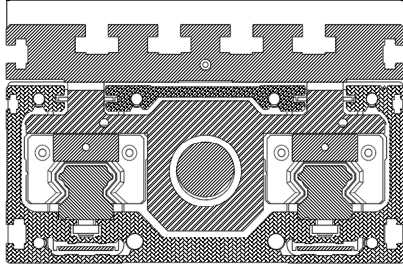

Opsiyon / Option

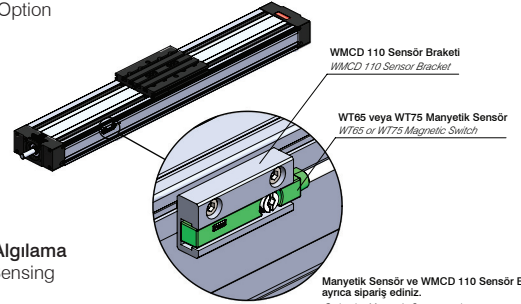
 Manyetik Algılama
Magnetic Sensing

 Manyetik Sensör ve WMCD 110 Sensör Braketini ayrıca sipariş ediniz.
Order the Magnetic Sensor and the WMCD 110 Sensor Bracket separately.

WMCD - BS - 110

- MS

4 - Strok / Stroke

0000 : Maksimum 1400 mm / *Maximum 1400 mm*

Hareket Stroku / Movement Stroke

 İstenilen çalışma strokuna ek olarak 2xHatve kadar her iki tarafta da boşluk bırakılması tavsiye edilir.
In addition to the desired movement stroke, it is recommended to leave a space on both sides until 2xPitch.

$$S_m = S_e + 2 \cdot S_s$$

$$S_s = 2 \cdot p$$

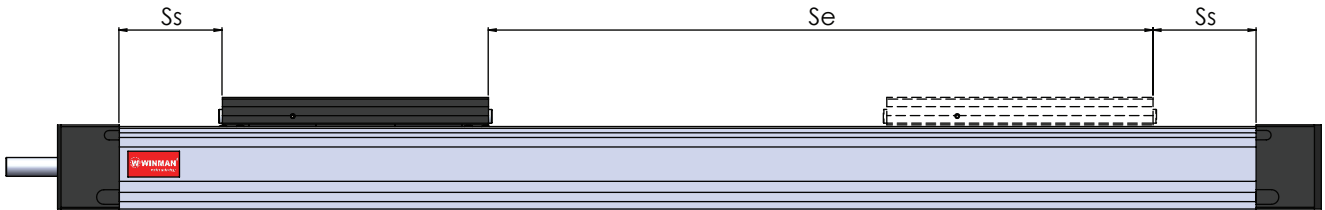
 S_m : Hareket Stroku / *Movement Stroke*
 S_e : Etkin Hareket Stroku / *Safety Stroke*
 p : Vidalı Mil Hatvesi / *Ball Screw Pitch*

5 - Hatve / Pitch

05 : 5 mm/devir / *5 mm/rev*
10 : 10 mm/devir / *10 mm/rev*
16 : 16 mm/devir / *16 mm/rev*

Sipariş Kodu / Ordering Code

WMCD - BS - 110 - - - - - -

1	2	3	4	5	6	7	8
Model Model	Tahrik Birimi Drive Unit	Boyut Size	Strok Stroke	Hatve Pitch	Bağlantı Kiti Modeli Mounting Kit Model	Bağlantı Kiti Montaj Mounting Kit Assembly	Bağlantı Kiti Yönü Mounting Kit Side

6 - Bağlantı Kiti Modeli / Mounting Kit Model

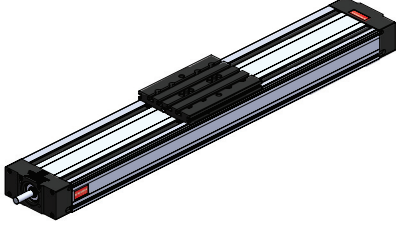
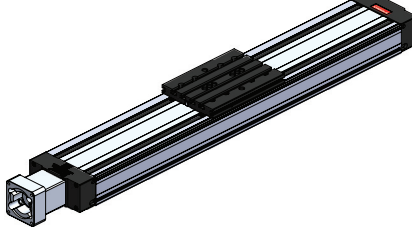
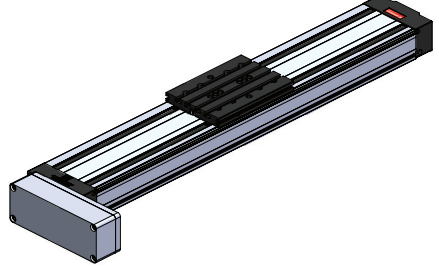
		
00 : Bağlantı Kitsiz (Standart) Without Mounting (Standard)	WDAK : Eksenel Kit Axial Kit	WDPK : Paralel Kit Parallel Kit

Not 1 : Farklı motor tipleri ve ölçüleri için irtibata geçiniz. *Note 1 : Please contact for different motor types and mounting sizes.*
 Not 2 : Redüktörlü ürünler kullanmak için irtibata geçiniz. *Note 2 : Please contact for to use reducer.*

7 - Bağlantı Kiti Montaj / Mounting Kit Assembly

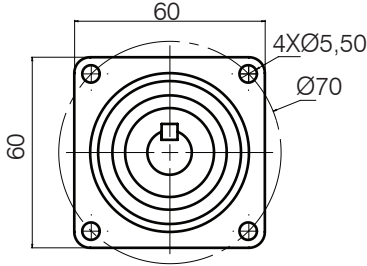
	
00 : Motorsuz (Standart) Without Motor (Standart)	070 : Ø70 motor bağlantısı Ø70 motor mounting

8 - Bağlantı Kiti Yönü / Mounting Kit Side

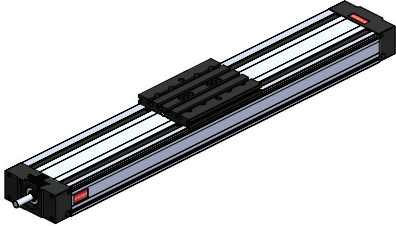
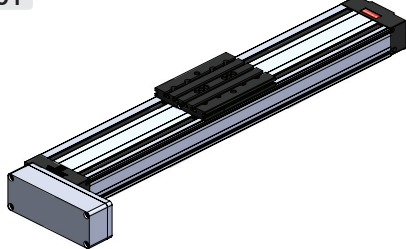
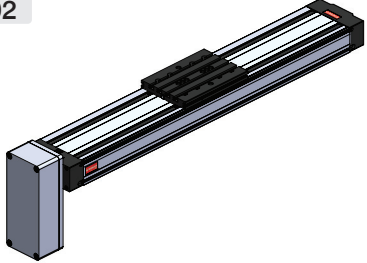
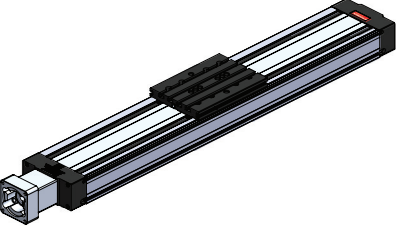
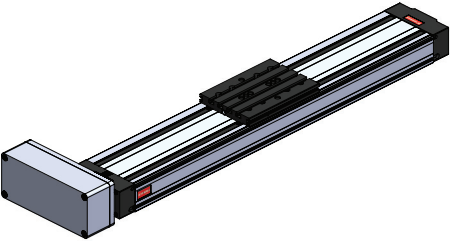
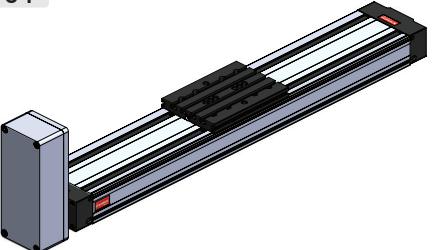
00 Standart / Standard 	01 	02 
	03 	04 

WINMAN WMCD-110 Serisi Kompakt Lineer Modül / WMCD-110 Series Compact Linear Module

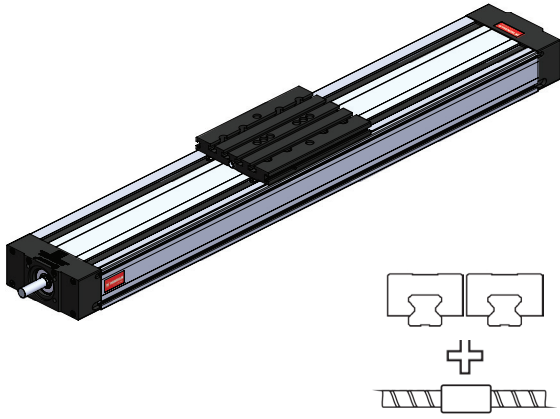

Özellikler / Specification

Maximum Strok / Maximum Stroke [mm]	1400
Pozisyonlama Hassasiyeti / Position Accuracy [$\mu\text{m}/\text{mm}$]	53/300
Tekrarlama Hassasiyeti / Repeating Accuracy [mm]	< 0,05
İvmelenme Max / Acceleration [m/s^2]	10

Hatve Screw Lead [mm]	Dinamik Yük Kapasitesi Dynamic Load Capacity [N]		Dinamik Moment Yük Kapasitesi Dynamic Torsional Moment Load Capacity [Nm]	
	C	C _{bs}	M _t	M _L
5	36960	9260	1890	3000
10		10420		
16		7350		

Eksenlerde İzin Verilen Max. Moment Max. Permissible Torsional Moment Around The Axis [Nm]			Eksenlerde Max. Dinamik Yük Max. Dynamic Load in Directions [N]		
M _x max	M _y max	M _z max	F _y max	F _{z1} max	F _{z2} max
700	1110	540	6660	13690	13690

Not : Verilen değerler teorik değerlerdir. Emniyet kat sayısını 5 almanızı öneririz.

Note : Calculated value are theoretical values. We recommend you to calculate safety factor as five(5).

Teknik Çizim / Technical Drawing

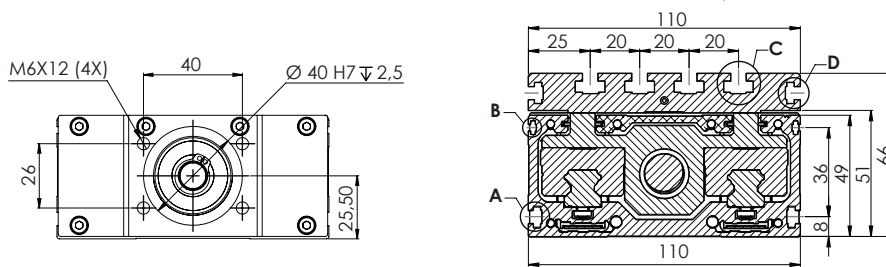
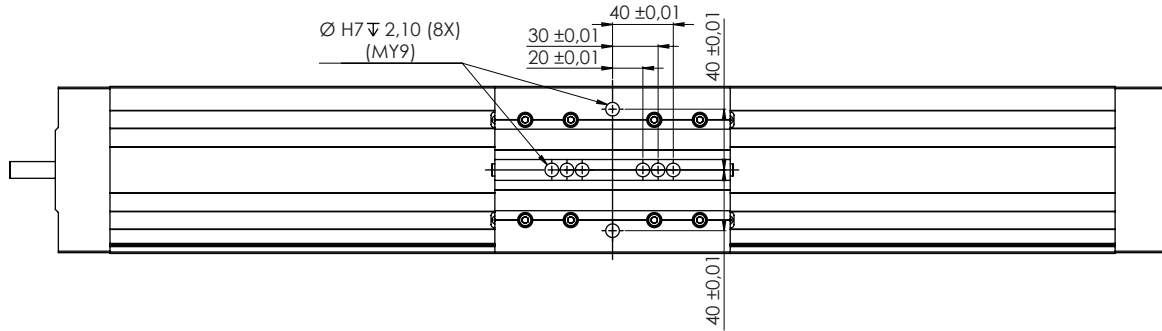
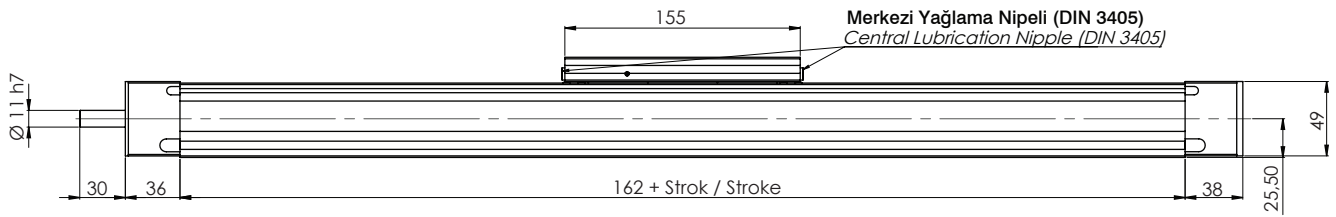
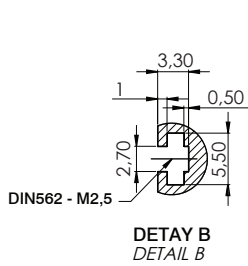
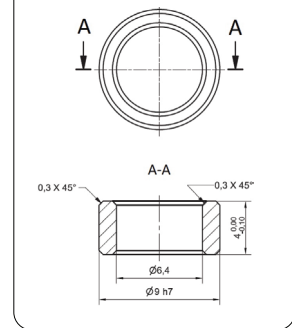
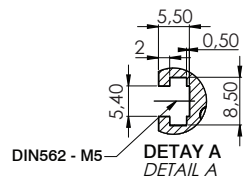
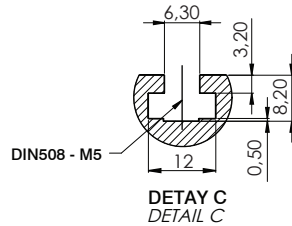
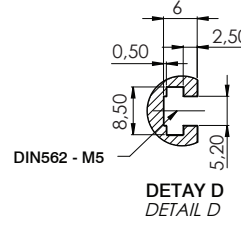
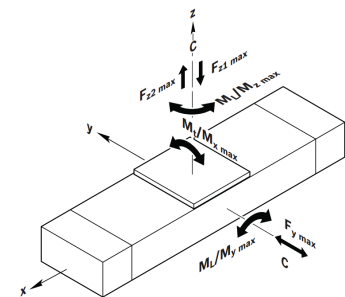
 MY9 Merkezleme Yüzüğü
MY9 Centering Ring

 DETAY B
DETAIL B

 DETAY A
DETAIL A

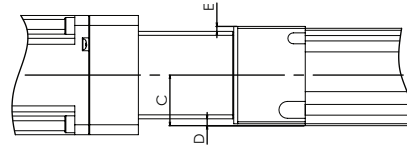
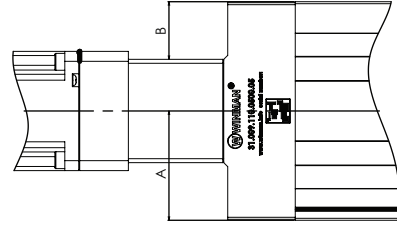
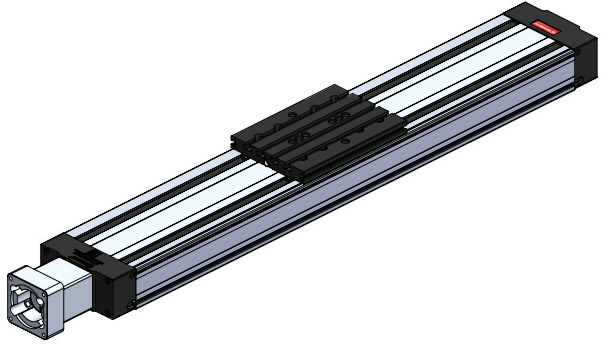
 DETAY C
DETAIL C

 DETAY D
DETAIL D

WDAK Eksenel Bağlantı Kiti / WDAK Axial Mounting Kit

Teknik Çizim / Technical Drawing



Bağlantı Kiti Tipi Mounting Kit Type	A	B	C	D	E
WDAK-070	55	29	25,50	3,50	2,50

Kampana / Bellhousing

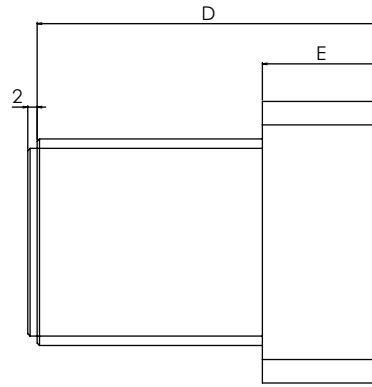
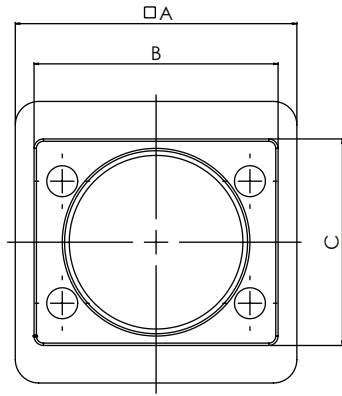

Bağlantı Kiti Tipi Mounting Kit Type	A	B	C	D	E
WDAK-070	60	52	44	73	25

Kaplin / Coupling

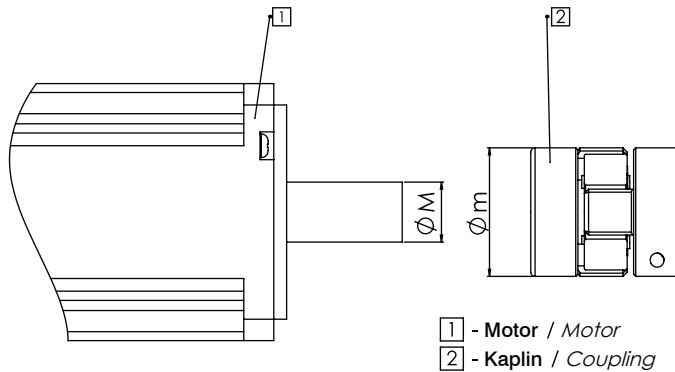

Bağlantı Kiti Tipi Mounting Kit Type	M	m	Kaplin Modeli Coupling Model
WDAK-070	14	30	WWJL - 30CRD

WDPK Paralel Bağlantı Kiti / WDPK - Parallel Mounting Kit

Teknik Çizim / Technical Drawing

WDPK - _ _ - 01

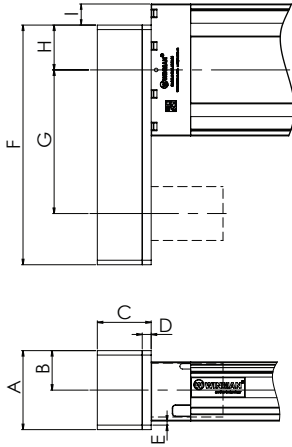
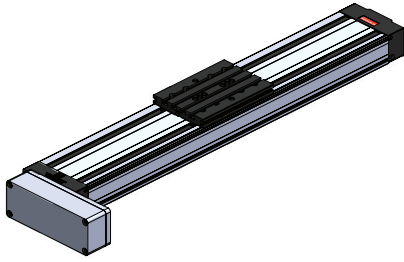

Kit Montaj Kit Assembly	WDPK - 070 - 01
A	64,50
B	32,25
C	50
D	10
E	6,75
F	179
G	100
H	39
I	15,50

WDPK - _ _ - 02

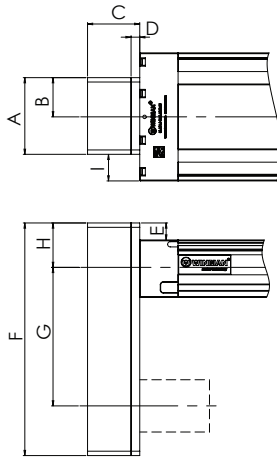
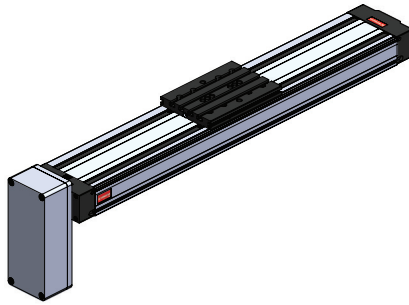

Kit Montaj Kit Assembly	WDPK - 070 - 02
A	64,50
B	32,25
C	50
D	10
E	14,50
F	179
G	100
H	39
I	22,25

WDPK - _ _ - 03

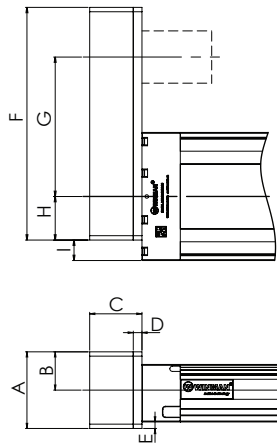
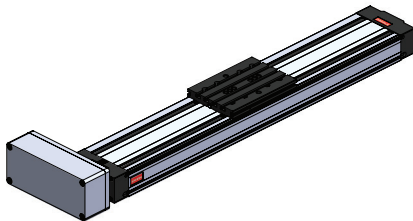

Kit Montaj Kit Assembly	WDPK - 070 - 03
A	64,50
B	32,25
C	50
D	10
E	7,50
F	179
G	100
H	39
I	15,50

WDPK - _ _ - 04

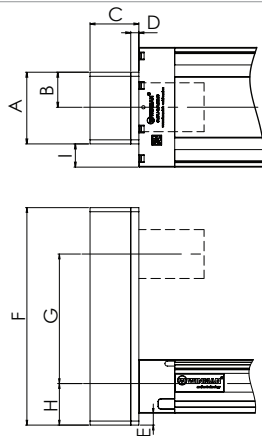
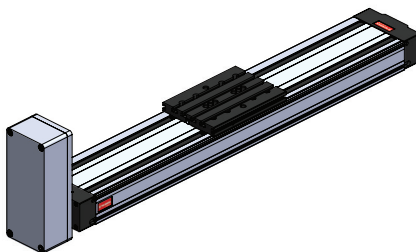

Kit Montaj Kit Assembly	WDPK - 070 - 04
A	64,50
B	32,25
C	50
D	10
E	14,50
F	179
G	100
H	39
I	22,50

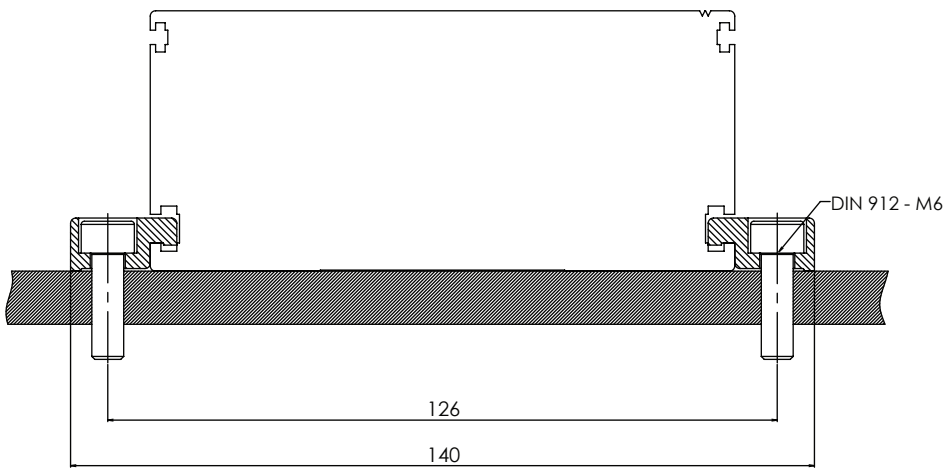
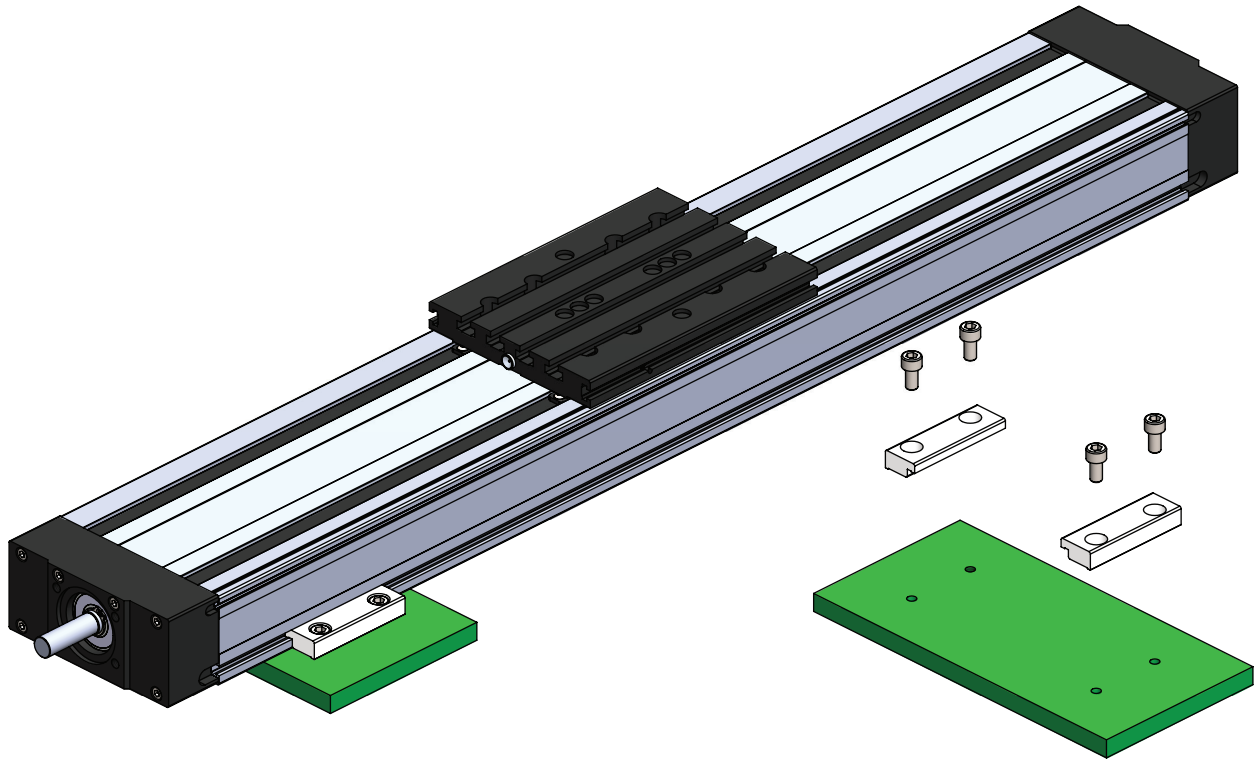
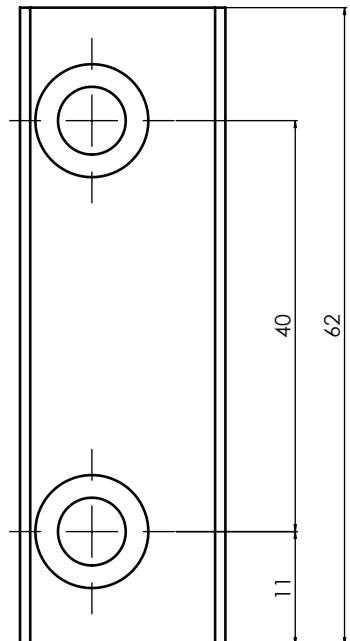
**WMCD 110 Sabitleme Braketi**
Clamping Fixtures

Montaj / Assembly

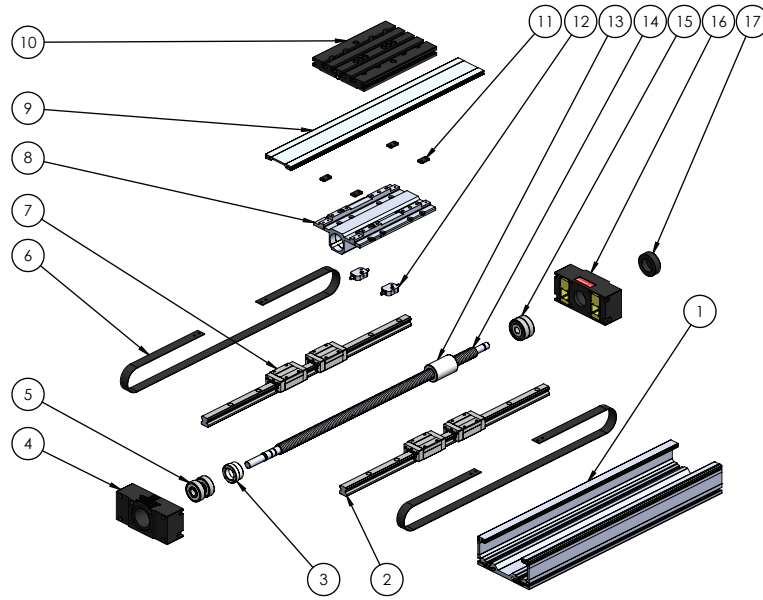
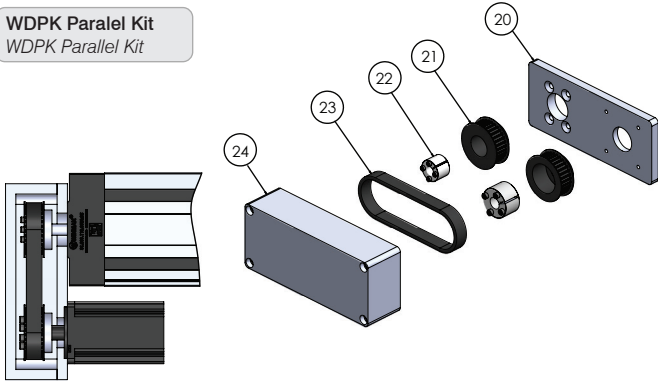
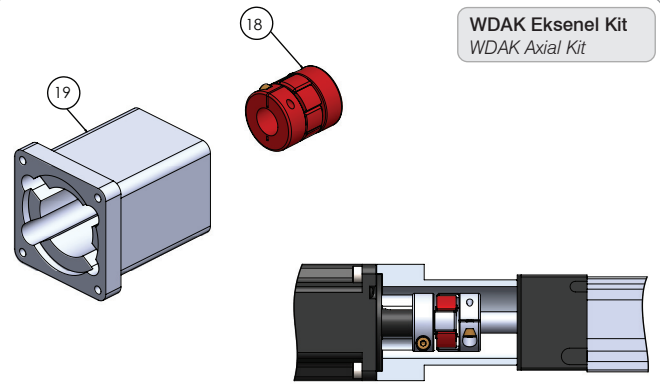
 WMCD Lineer Modül
 WMCD Linear Module

 WDPK Paralel Kit
 WDPK Parallel Kit

 WDAK Eksenel Kit
 WDAK Axial Kit

Parça Piece	Miktar Qty	Parça Adı Part Name	Montaj Assembly
1	1	Profil / Profile	Modül Module
2	2	Lineer Ray / Linear Guide	
3	1	Ön Rulman Baskı Somunu / Front Bearing Pressure Nut	
4	1	Ön Kapak / Front Block	
5	2	Ön Yataklama Rulmanı / Front Bearing	
6	2	Korozyona Dayanıklı Koruma Şeridi / Protection Strip Corrosion Resistans	
7	4	Lineer Araba / Linear Carriage	
8	1	Bağlantı Plakası / Mounting Plate	
9	1	Taşıyıcı / Carriage	
10	1	Profil Kapağı / Profile Cover	
11	4	Şerit Bağlantı Parçası / Strip Mounting Piece	
12	2	Yağlama Portu / Lubrication Port	
13	1	Vidalı Somun / Ball Nut	
14	1	Vidalı Mil / Ballscrew	
15	1	Arka Yataklama Rulmanı / Back Bearing	
16	1	Arka Kapak / Back Block	
17	1	Arka Rulman Baskı Somunu / Back Bearing Pressure Nut	
18	1	Kaplin / Coupling	Eksenel Kit Axial Kit
19	1	Kampana / Bellhousing	Paralel Kit Parallel Kit
20	1	Paralel Kit Kapağı / Parallel Kit Cover	
21	2	Dişli Kasnak / Timing Belt Pulleys	
22	2	Konik Burç / Trapez Bushing	
23	1	Dişli Kayış / Toothed Belt	
24	1	Paralel Kit Kutusu / Parallel Kit Box	

Bakım / Maintenance

-İlk yağlama üretim sırasında yapılır.

Basic lubrication is done in-factory before shipment.

-Vidalı mili yataklayan rulmanlar, normal çalışma koşullarında tekrardan yağlama gerektirmez.

Bearings of the ball screw have been lubricated for life and will not require in-service lubrication under normal operating conditions.

- Bilyeli somun ve taşıyıcı arabaların yağlaması tek porttan yapılır.

The lubrication of ball nuts and carriages is made from a single port.

- Kompakt modüller sadece uygun gres ile yağlanmalıdır.

Compact modules must be lubricated with suitable grease.

- Lityum içerikli gres yağlar kullanılmalıdır.

Lithium soap grease should be used.

-Dikkat: grafit ya da MoS içeren gresler tercih etmeyiniz!

Caution: Do not use grease containing graphite or MoS!

-Yağlama, her 400 çalışma saatinde ya da 400km çalışma mesafesine ulaşıldığında yapılır.

Lubrication is performed every 400 hours or 400 km total working distance by normal operating conditions.

-Yağlama miktarları normal çalışma koşullarına göre tabloda verilmiştir.

Lubrication quantities is provided in table by normal operating conditions.

-Yağlamadan sonra lineer modülü, strok boyunca en az üç kez hareket ettirin. Hareket sırasında, hareket hızı 10 mm/sn değerini aşmamalıdır.

After lubrication, move the linear module at least three times. Do not exceed the movement value, the movement speed 10 mm / s.

- Paralel Kitlerdeki kayış ve kasnaklar arasında sabit bir eksen mesafesi ile monte edilir. Bu nedenle kayış gerginliğini ayarlamaya gerek yoktur.

Belt is assembled with a fixed axis distance between the pulleys in Parallel Kits. In consequence there is a no need to adjust the tension of belt.

-Bakım sonrasında, modüldeki koruma şeridi gerginliği için bilgi alınız.

After maintenance, get information about the protection strip tension on the module.

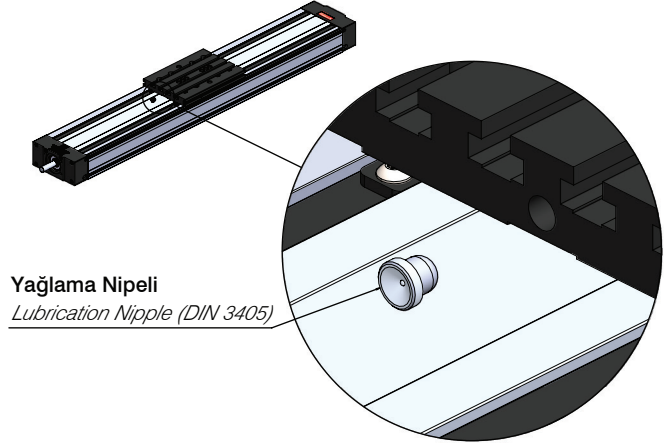

Normal Çalışma Koşulları / Normal Working Conditions

Not : Tabloda belirtilen yağlama miktarı normal çalışma koşulları için geçerlidir. Farklı çalışma koşullarında yağlama miktarı değişkenlik gösterebilir. Farklı çalışma şartlarında ki yağlama miktarı için bilgi alınız.

Note : The lubrication quantity specified in the table is valid for normal operating conditions. The lubrication quantity may vary in different operating conditions. Get information for the lubrication quantity in different working conditions.

Ortam Sıcaklığı / Ambient Temperature	°C	10 ~ 40
Çalışma Hızı / Speed	m/s	≤ 1,0
Vidalı Mil Dönme Hızı / Screw Rotation Speed	rev/min	2500
Yük / Load	kN	≤ 0,2 C
Strok / Stroke	mm	> 60
Yağlama Periyodu / Lubrication Period	Km	400
	Hour	400
Yağlama Miktarı / Lubricate Dose	cm ³	5,2