

## WINMAN GVR Series Vacuum Regulator

### Compendium of GVR Series

#### Pressed-in self-locking mechanism

The pressed-in self-locking mechanism can prevent the abnormal movement of the set pressure caused by external interfere.

#### Suitable to adjust the vacuum pressure

#### Panel installation and bracket installation are optional

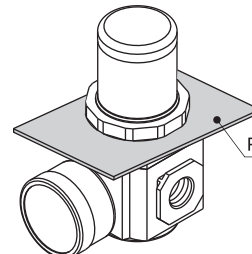

Panel installation

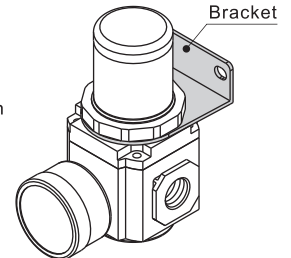

Bracket installation

### Flow chart and Pressure chart

#### Flow chart

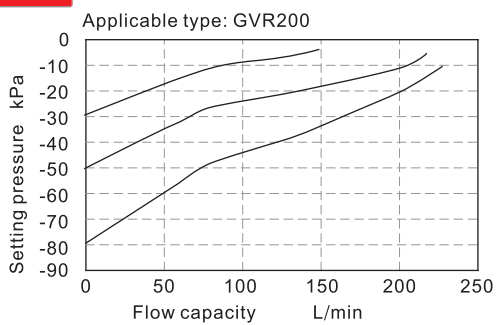

#### Pressure chart

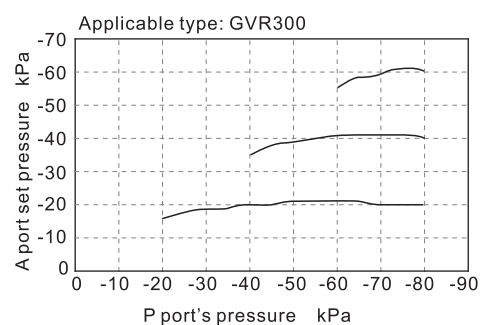
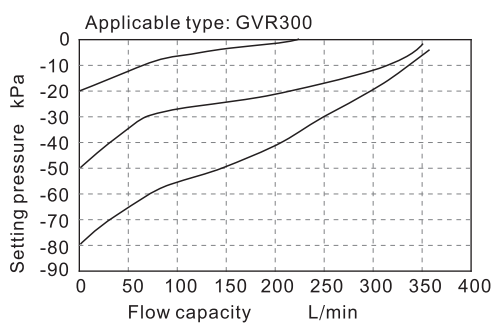
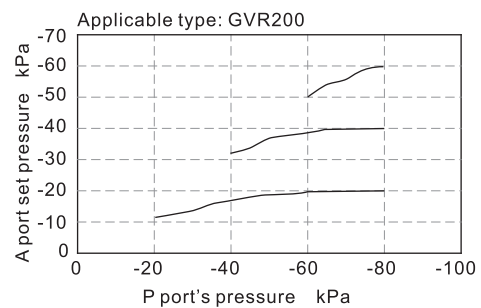

### Installation and Application

1. Please be used with safety circuit to avoid accidents when power failure, vacuum pump and vacuum regulator fail.
2. When checking, please set the pressure to 0 (atmospheric pressure) and completely cut off the pressure of the vacuum pump before pulling down the tube of the regulator.
3. The vacuum regulator can not be used to regulate the pressure of the vacuum pump, if the flow capacity of the vacuum generator is less than the flow capacity of the vacuum regulator, it is not suitable as a vacuum source.
4. The regulating knob rotates clockwise, the atmospheric pressure changes to the vacuum pressure, turns counterclockwise, the vacuum pressure changes to atmospheric pressure.
5. After setting the pressure, press the button on the pressure adjusting button until you hear the click.
6. The vacuum regulator is used for negative pressure, and no positive pressure should be applied.

## WINMAN GVR Series Vacuum Regulator



### Specification

Model	GVR200-06	GVR200-08	GVR300-08	GVR300-10
Fluid	Air			
Port size [Note1]	1/8"	1/4"	1/4"	3/8"
Pressure range	-100~1.3kPa			
Max. Pressure	-1.0kPa			
Air inhalation consumption	0.6L/min(ANR)and bellow			
Temperature range	-20-70°C			
Applicable Tube	204	198	342	336

[Note1] NPT thread and G thread are available.

### Symbol

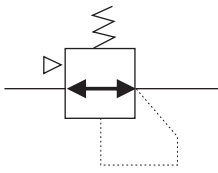

### Product features

- 1.The pressed-in self-locking mechanism can prevent the abnormal movement of the set pressure caused by external interference.
- 2.The pressure regulation is stable, the drift is small and the pressure characteristic is good.
- 3.In addition to panel installation, the bracket is optional for installation.

### Ordering Code

GVR300 - 10 □ □ □

1 2 3 4 5

1 Model	GVR200:200 series vacuum regulator	GVR300:300 series vacuum regulator
2 Port size	06:PT1/8 08:PT1/4	08:PT1/4 10:PT3/8
3 Accessories	Blank: Bracket J: No bracket	
4 Pressure gauge	Blank: Pressure gauge N: No pressure gauge	
5 Thread type	Blank: PT (kPa & psi) G: G (kPa & psi) T: NPT (kPa & psi)	

### Inner structure

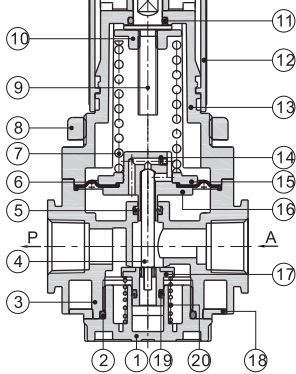

No.	Item	Material	No.	Item	Material
1	Valve cap	POM	11	O-ring	NBR
2	O-ring	NBR	12	Pressure knob	POM
3	Body	Aluminum alloy	13	Adjusting seat	POM
4	Spool	Aluminum alloy	14	Gas resistance	Aluminum alloy
5	O-ring	NBR	15	Diaphragm up core	Aluminum alloy
6	Diaphragm	NBR	16	Diaphragm down core	Aluminum alloy
7	Spring	SWC	17	Pressure plug	Aluminum alloy
8	Fixed ring	PA66+Glass fibre	18	Bottom cover	POM
9	Adjusting spindle	Steel	19	O-ring	NBR
10	Regulator nut	Steel	20	Spring	Stainless steel

## WINMAN GVR Series Vacuum Regulator

### Dimensions

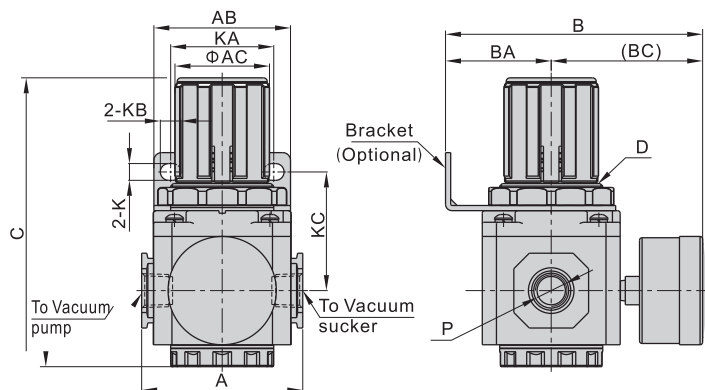

Model/Item	A	AB	AC	B	BA	BC	C	D	K	KA	KB	KC	P
GVR 20006	52.5	55	31	83	30	53	89	M33X1.5	5.4	34	15.4	15.4	1/8"
GVR 20008	52.5	55	31	83	30	53	89	M33.1.5	5.4	34	15.4	15.4	1/4"
GVR 30008	62.5	53	38	99.5	41	58.5	112	M40X1.5	6.5	40	8	8	1/4"
GVR30010	62.5	53	38	99.5	41	58.5	112	M40X1.5	6.5	40	8	8	3/8"