

**WINMAN Solenoid Valfler (2/2 yollu) / Fluid control valve (2/2 way)**

2W Serisi (Doğrudan etkili ve normalde kapalı) / 2W Series ( Direct-acting and normally closed )

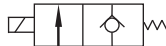

Sembol / Symbol



**Ürün Özelliği / Product Feature**

1. Direct acting and normally closed type 2/2 way solenoid valve. Its high sensibility allows it to change direction quickly;
2. It has wide pressure range, including extra high pressure (X), high pressure (H), standard , large volume(L) and extra large volume (T) to choose from;
3. It is compact, small size and light weight. It is easy to install and dismantle.
4. The valve body is made of brass . Its coil has a Heat resistance classification of Class B. The standard seal material is FPM-F. Please contact us if other material are required.
5. The protection class of the coil is IP65 and there is a choice for grommet or terminal electrical entry .

**İç yapı / Inner structure**

2W030 (Terminal)

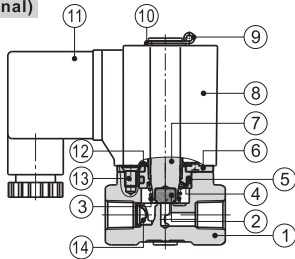

No.	Item	No.	Item
1	Body	8	Coil assembly
2	Airtight ring	9	E Clip
3	Spring	10	Gasket
4	Fixed cap	11	Connector
5	O-ring	12	Washer
6	Fixed plate	13	Screw
7	Movable core	14	Filter [Note]

[Note] Extra large volume type has no filter element.

**Sipariş Kodu / Ordering Code**

Ordering code of valves

**2W L 030 08 A** □ □



① Model	② Pressure condition	③ Size series	④ Port size	⑤ Voltage	⑥ Electrical entry	⑦ Thread type
2W: 2/2 way direct-acting and normally closed	X: Extra high pressure H: High pressure Blank: Standard L: Large volume T: Extra large volume	030: 030 Series  050: 050 Series	06: 1/8" 08: 1/4"  10: 3/8" 15: 1/2"	A: AC220V B: DC24V C: AC110V E: AC24V F: DC12V	Blank: Terminal I: Grommet	Blank: PT G: G T: NPT

**Ordering code of accessories**

Ordering code of accessories is the same as 2S series valve's, Please refer to P148 for details of ordering code.

**Özellikler / Specification**

Model/Item	Port size [Note1]	Orifice size (Φmm)	Cv	Valid area or section (mm²)	Weight [Note2](g)	Max. operating pressure differentia		Proof pressure	
						MPa	psi	MPa	psi
2WX030	-06 1/8"	1.5	0.10	1.8	305	3.0	450	5.0	750
	-08 1/4"				295				
2WH030	-06 1/8"	2.0	0.18	3.0	305	2.0	300		
	-08 1/4"				295				
2W030	-06 1/8"	3.0	0.33	6.0	305	1.0	150		
	-08 1/4"				295				
2WL030	-06 1/8"	4.0	0.55	10.0	305	0.5	75		
	-08 1/4"				295				
2WT030	-06 1/8"	6.0	1.10	12.0	305	0.1	15		
	-08 1/4"				295				
2WX050	-10 3/8"	3.0	0.34	6.1	620	3.0	450		
	-15 1/2"				600				
2WH050	-10 3/8"	4.0	0.55	10.0	620	2.0	300		
	-15 1/2"				600				
2W050	-10 3/8"	5.0	0.83	15.0	620	1.0	150		
	-15 1/2"				600				
2WL050	-10 3/8"	7.0	1.40	25.0	620	0.5	75		
	-15 1/2"				600				
2WT050	-10 3/8"	10.0	2.20	40.0	620	0.1	15		
	-15 1/2"				600				

[Note1] PT thread, G thread and NPT thread are available.

[Note2] The weight in the table is the terminal valve's weight, 2W030 series grommet valve's weight is 10g less than terminal's. 2W050series grommet valve's weight is 20g less than terminal's.

**Bobinin özellikleri / Specification of coil**

Valve type	Coil type	Power type	Frequency (Hz)	Voltage range	Electrical entry	Power Consumption (VA/W)	Insulation	Temp. rise(°C)	
2W□030	CDA116 CLA116	AC	50	± 15%	Terminal (CDA)	10.0VA	Class B	35	
			60			8.0VA		30	
		DC	-	± 10%		6.5W		30	
2W□050	CDA170 CLA170	AC	50	± 15%	Grommet (CLA)	25.0VA		Class B	60
			60			22.0VA			55
		DC	-	± 10%		10.5W			40

**Vana spesifikasyonu / Valve's specification**

Acting	Direct acting				
Initial state	Normally closed				
Adaptable fluid	Air, Water, Oil				
Viscosity limit	Under 20CST				
Ambient and fluid temperature ( °C )	Water	Air	Oil	Ambient	
	Max.	80	90	80	70
	Min.	1	-20 [Note1]	-10 [Note2]	-20

[Note1] Dew point: -20(°C) or less;

[Note2] 50CST or less.

**WINMAN Solenoid Valfler (2/2 yollu) / Fluid control valve (2/2 way)**

2W Serisi (Doğrudan etkili ve normalde kapalı) / 2W Series ( Direct-acting and normally closed )

**Akış Şeması / Flow Chart**

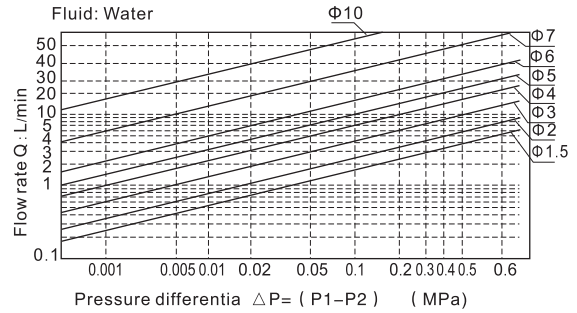
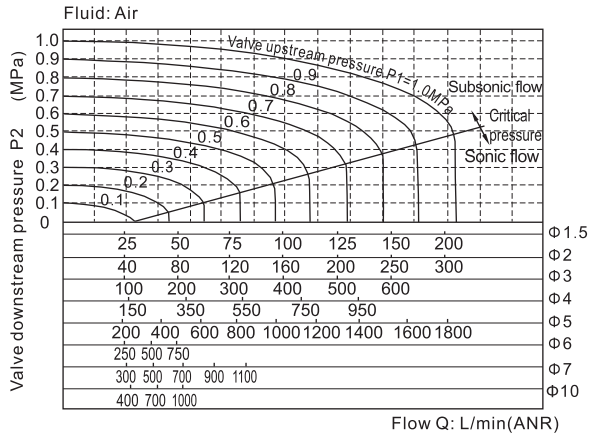

**Boyutlar / Dimensions**

**2W□030 (Terminal)**

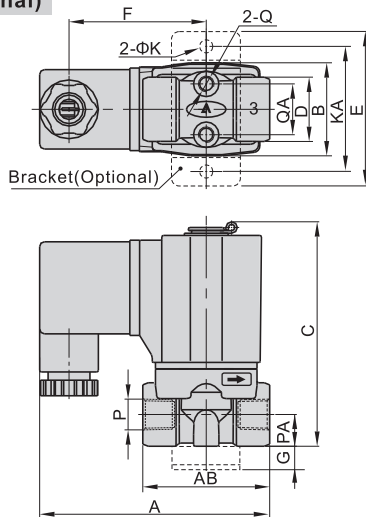

**2W□030 (Grommet)**

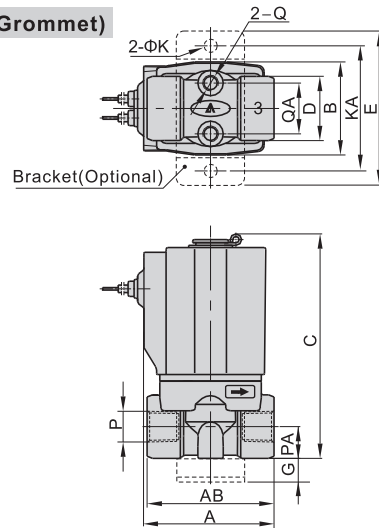

**2W□050 (Terminal)**

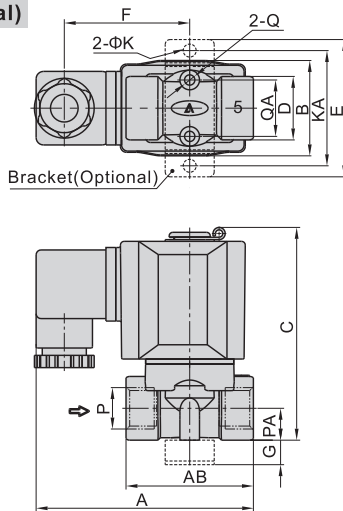

**2W□050 (Grommet)**

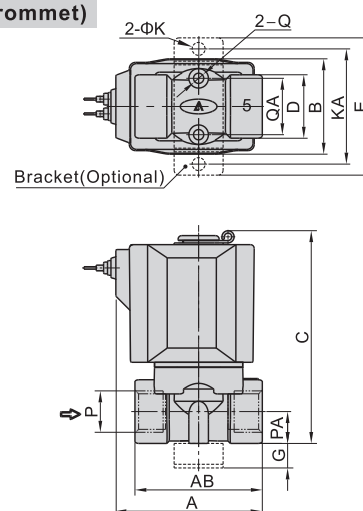

Model\Item	A	AB	B	C	D	E	F	G	K	KA	P	PA	Q	QA
2W□030-06	72.5	40	29.5	71	20	49	43.5	10	5.3	40	1/8"	10	M5	16
2W□030-08	72.5	40	29.5	71	20	49	43.5	10	5.3	40	1/4"	10	M5	16
2W□050-10	89.5	52	39	87	26	56	51	10	5.3	48	3/8"	13	M5	23
2W□050-15	89.5	52	39	87	26	56	51	10	5.3	48	1/2"	13	M5	23

Model\Item	A	AB	B	C	D	E	G	K	KA	P	PA	Q	QA
2W□030-06	41	40	29.5	71	20	49	10	5.3	40	1/8"	10	M5	16
2W□030-08	41	40	29.5	71	20	49	10	5.3	40	1/4"	10	M5	16
2W□050-10	60	52	39	87	26	56	10	5.3	48	3/8"	13	M5	23
2W□050-15	60	52	39	87	26	56	10	5.3	48	1/2"	13	M5	23